

X036/12/01

NATIONAL
QUALIFICATIONS
2014

THURSDAY 15 MAY
1.00 PM – 4.00 PM

TECHNOLOGICAL
STUDIES
HIGHER

200 marks are allocated to this paper.

Answer **all** questions in Section A (120 marks).

Answer **two** questions from Section B (40 marks each).

Where appropriate, you may use sketches to illustrate your answer.

Reference should be made to the Higher Data Booklet (2008 edition) which is provided.

A Worksheet has been provided for Question 11.



SECTION A

Attempt all the questions in this Section. (Total 120 marks)

Marks

1. The speed at which the paper feeds through a printer is selected by a PBASIC sub-procedure *feedspeed*. The sub-procedures *fine* and *draft* control the speed of the paper-feed motor using pulse-width modulation (PWM), for two different feed rates. A flowchart for *feedspeed* is shown in Figure Q1(a), and for *draft* in Figure Q1(b). The relevant microcontroller connections are shown in Figure Q1(c).

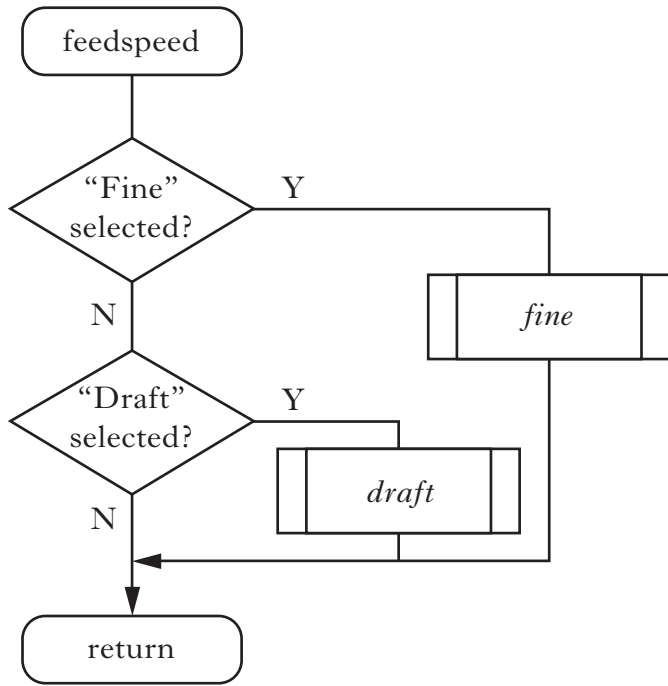

Figure Q1(a)

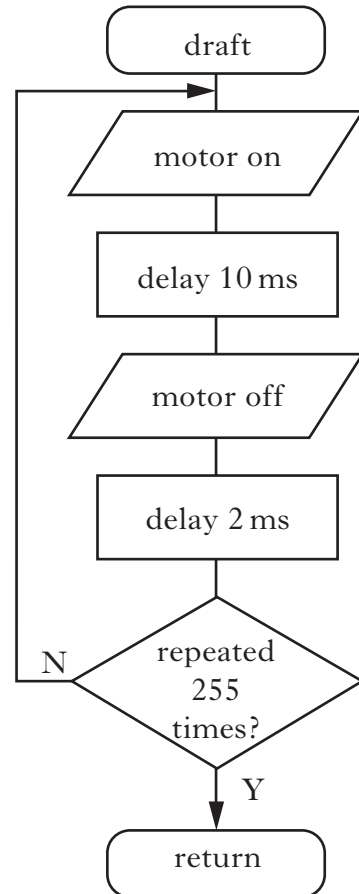

Figure Q1(b)

INPUTS	PIN	OUTPUTS
“Fine” select switch	1	
“Draft” select switch	2	
	7	Motor

Figure Q1(c)

(a) Write, in PBASIC, the sub-procedures:

(i) *feedspeed*;

7

(ii) *draft*.

5

Sub-procedure *fine* has a mark:space ratio of 1:3 and it repeats 255 times in 3.06 seconds.

(b) Calculate the “mark” and “space” times required for sub-procedure *fine*.

4

2. The control panel for the climate-control system in a car is shown in Figure Q2(a). A combinational-logic system controls the operation of a compressor (C).
 An air-conditioning select switch (A), a windscreen-demist switch (D), and a temperature sensor (T) provide input signals to the combinational-logic system.

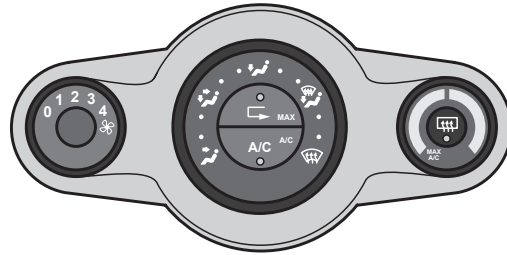

Figure Q2(a)

A truth table for the system is shown in Figure Q2(b).

Air-conditioning Select (A)	Windscreen Demist (D)	Temperature Sensor (T)	Compressor (C)
0	0	0	0
0	0	1	0
0	1	0	1
0	1	1	0
1	0	0	1
1	0	1	0
1	1	0	1
1	1	1	0

Figure Q2(b)

- (a) Write a Boolean equation for the compressor (C), in terms of A, D and T. 4

The compressor will operate only if the temperature sensed is above 5 °C.

- (b) State the logic value of the temperature sensor at 6 °C. 1

- (c) Draw a combinational-logic system to control the compressor using AND, OR and NOT gates. 6

- (d) Draw an equivalent logic system using only NAND gates. Simplify where possible. 6

(17)

3. The joint shown in Figure Q3(a) forms part of the roof structure of a new museum.

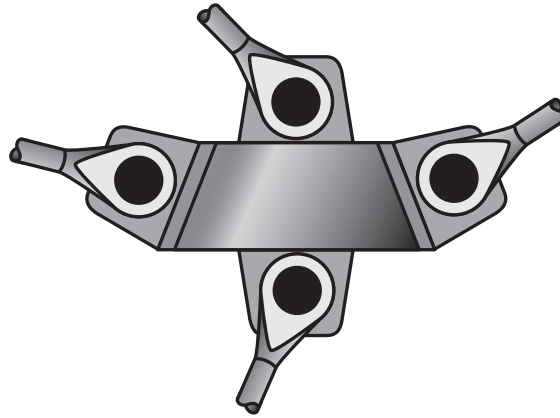

Figure Q3(a)

The forces acting on the joint are in **static equilibrium** and are shown *in simplified form* in Figure Q3(b).

- (a) Explain the meaning of the term “static equilibrium”.

2

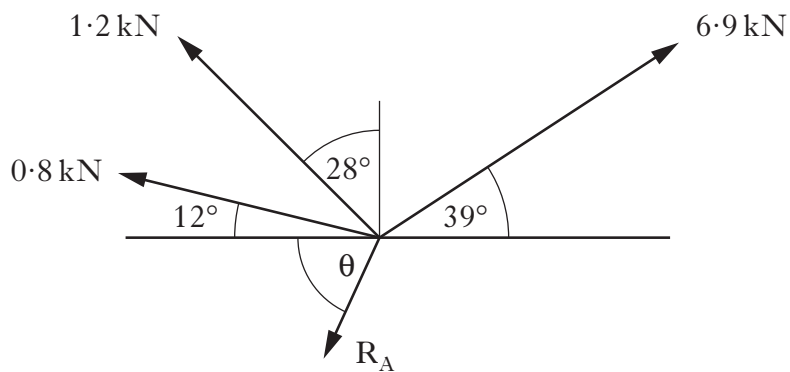

Figure Q3(b)

- (b) Calculate the magnitude of the reaction force R_A and the angle θ .

12

(14)

4. The circuit shown in Figure Q4(a) is used to control the operation of a motorised valve in a central-heating system.

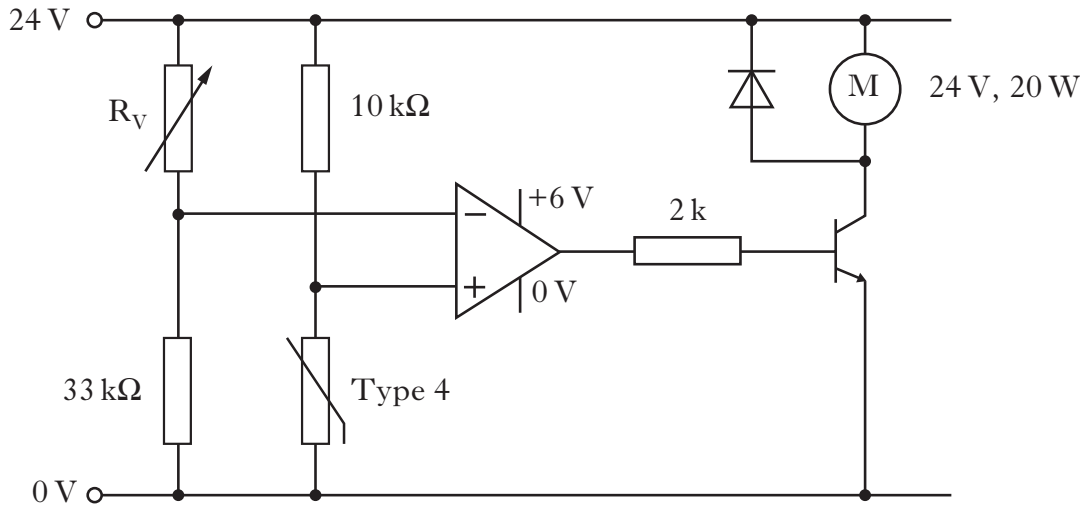

Figure Q4(a)

The motor should operate when the room temperature sensed by the thermistor is 16 °C.

- (a) Calculate the required value of resistor R_V . 3
- (b) Calculate the minimum required gain of the transistor. 6
- (c) Explain the reason for the inclusion of a diode in this circuit. 2

The motorised valve is to be replaced by another unit containing a motor rated at 24 V, 50 W. This motor requires a Darlington Pair driver circuit.

- (d) (i) Calculate the minimum current gain required to operate the new valve. 4
- (ii) Sketch the required transistor circuit. 3

The first transistor in the Darlington Pair is a BC182L with the operating characteristics shown in Figure Q4(b).

- (e) Calculate the minimum required current gain for the second transistor in the Darlington Pair. 3

(21)

Device	$V_{CE \text{ max}}$ (V)	$I_C \text{ max}$ (mA)	h_{FE}
BC107	45	200	100
BC182L	50	100	120
2N3705	30	600	50

Figure Q4(b)

5. The hot tub shown in Figure Q5 uses a two-state closed-loop control system to regulate the water to a desired temperature.

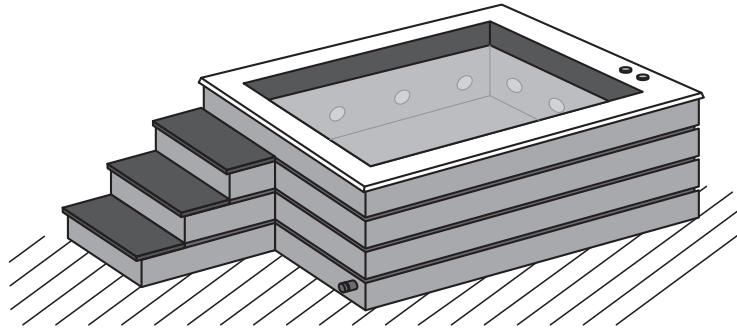

Figure Q5

- (a) For the hot-tub temperature control system:

(i) draw a control diagram;

6

(ii) state the name of the operational amplifier (op-amp) configuration used in this type of control.

1

- (b) Sketch a graph of temperature against time. Show a desired temperature and show how the temperature of the water changes as it is heated from a lower temperature.

4

- (c) The control system is replaced by a closed-loop proportional control system.

(i) State the name of the op-amp configuration used in this type of control.

1

(ii) Sketch a graph of temperature against time showing the ideal response of a proportional control system, as the water is heated from a temperature below the required value.

2

(14)

6. Figure Q6 shows the load-extension graph produced during a tensile test performed on an alloy-steel specimen.

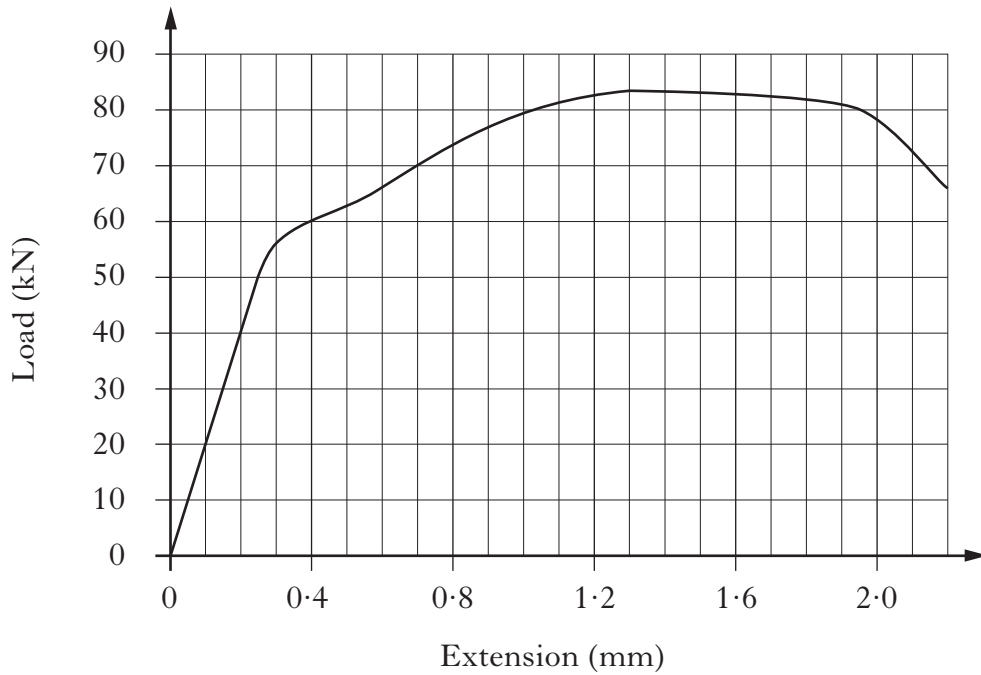

Figure Q6

The test specimen was 120 mm long with a rectangular cross-section of 26 mm × 6 mm.

- (a) Calculate Young's Modulus for this material. 7
- (b) Describe the effect on the specimen of **applying** and then **removing** the following loads:
- (i) 50 kN; 2
 - (ii) 80 kN. 2

(11)

[Turn over

7. The pick-and-place robotic arm shown in Figure Q7(a) lifts components from a conveyor and places them onto a rack. The arm is controlled by a microcontroller.

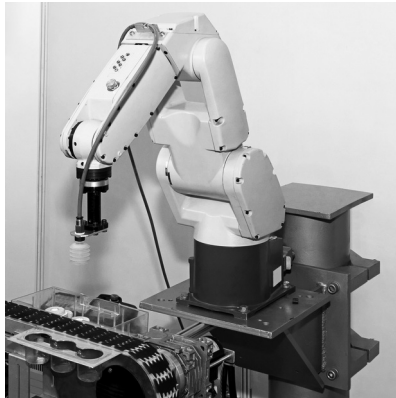

Figure Q7(a)

A sub-procedure *place* picks up one component at a time and places it onto the rack.

A pre-written sub-procedure *moverack* repositions the rack after each component has been placed.

When 18 components have been placed, the rack is full.

The specification for sub-procedure *place* is as follows:

- close gripper until limit-switch is high
- arm motor forwards for 3·2 seconds
- open gripper until limit-switch is low
- arm motor backwards for 3·2 seconds
- call sub-procedure *moverack*
- if 18 components have been placed, sub-procedure ends.

Draw a flowchart to represent the sub-procedure *place*.

16

(16)

8. The circuit shown in Figure Q8 is used to amplify the signal produced by a flow sensor in part of a chemical plant.

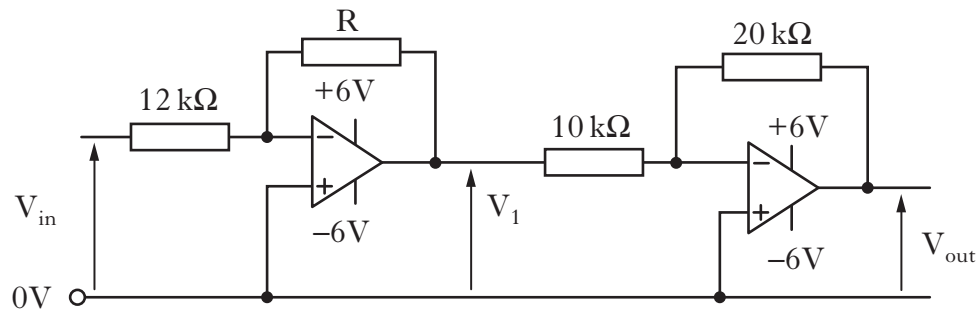

Figure Q8

- (a) (i) State the name of the op-amp configuration used in the circuit shown in Figure Q8. 1
- (ii) Explain the reasons for the inclusion of the second op-amp in this circuit. 2
- (b) Calculate the required value of resistor, R , so that V_{out} reaches its maximum value when V_{in} is 0.68 V . 8
- (11)**

[END OF SECTION A]

[Turn over

SECTION B

Marks

Attempt any TWO questions in this Section.

Each question is worth 40 marks.

9. The framework shown in Figure Q9(a) represents the jib-arm of a wall-mounted crane.

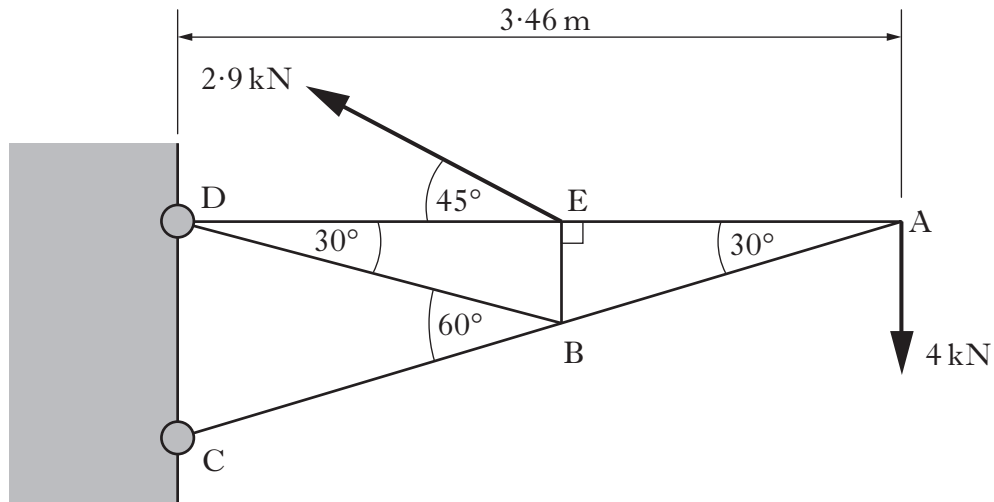

Figure Q9(a)

For a load of 4 kN acting at A:

- (a) calculate the magnitude of the reaction force at C by taking moments about D; **9**
- (b) calculate the magnitude and nature of the forces in members AB, AE and BD. **10**

Two strain gauges are positioned on member AE. One of the strain gauges is active and the other is passive.

- (c) Explain the reason for the use of a passive strain gauge. **2**

9. (continued)

Marks

An alarm sounds if the force acting in member AE is too high. The overload alarm circuit is shown in Figure Q9(b) below, with the strain gauges showing their values when the alarm is activated.

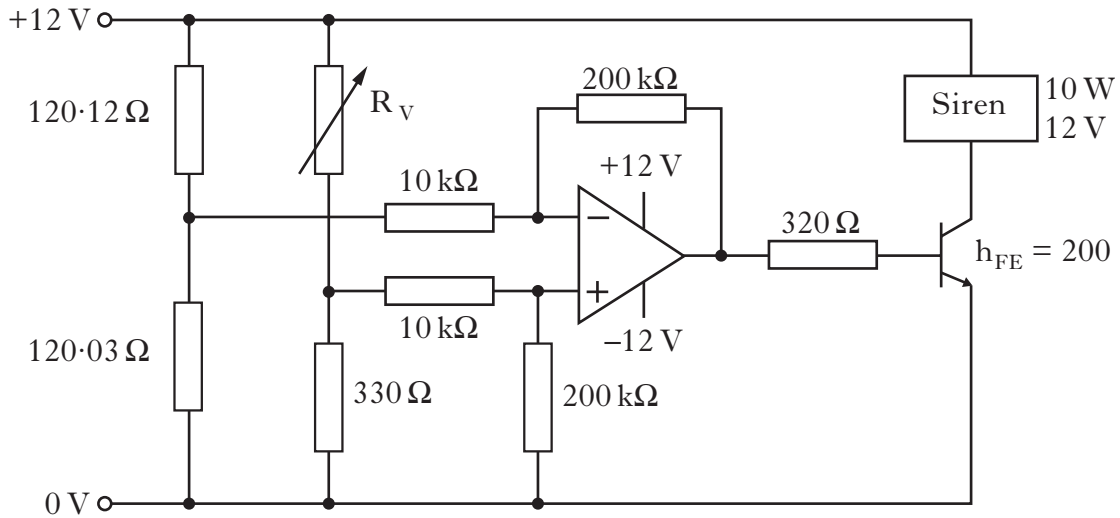

Figure Q9(b)

- (d) Calculate the maximum value of the variable resistor R_v required so that the siren operates for the conditions shown in Figure Q9(b). 13

A visual overload-warning system is used, as shown in Figure Q9(c), in case the operator is unable to hear the siren. V_{in} is the signal from the overload alarm circuit.

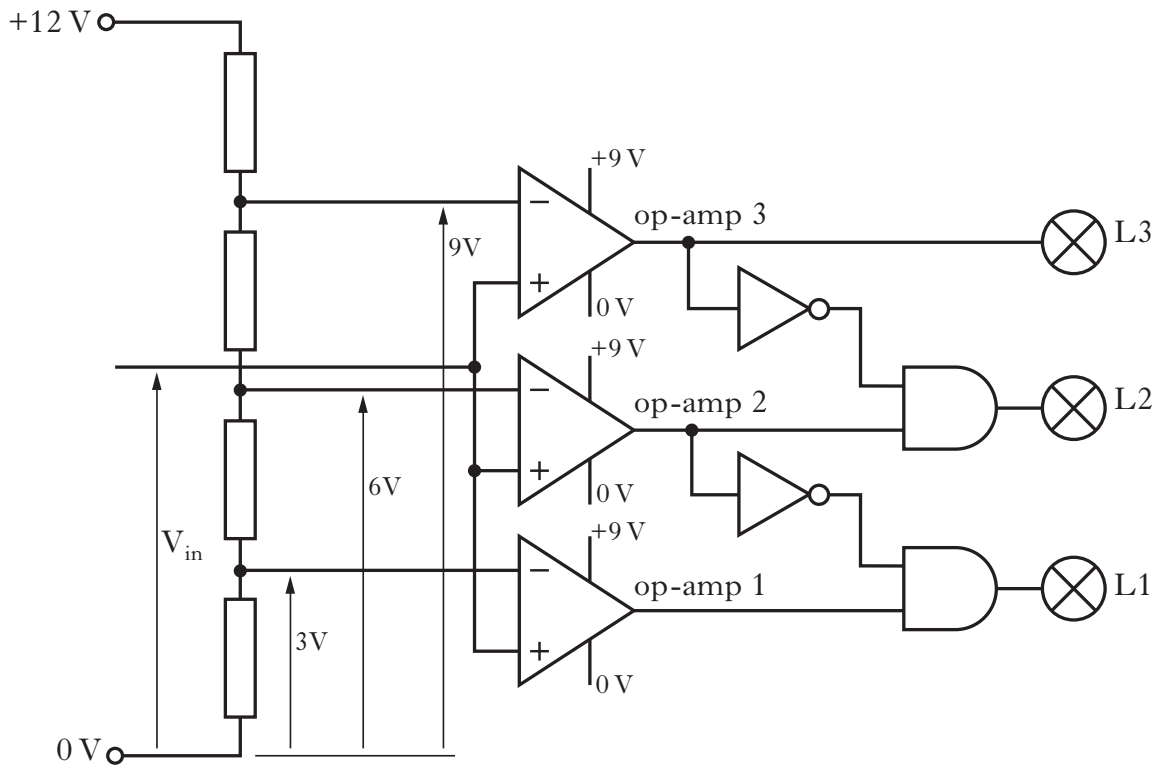

Figure Q9(c)

- (e) Describe the operation of the warning circuit, in terms of Input, Process and Output, as the force in member AE increases.

10. A microcontroller-based warning system monitors the tyres of a lorry for high and low tyre pressures. Each wheel has a processor unit containing a pressure sensor, a temperature sensor, and a microcontroller. A built-in radio-frequency transmitter sends data to a receiver which is connected to dashboard warning lamps. Figure Q10(a) shows a block diagram representing the system for one wheel processor-unit.

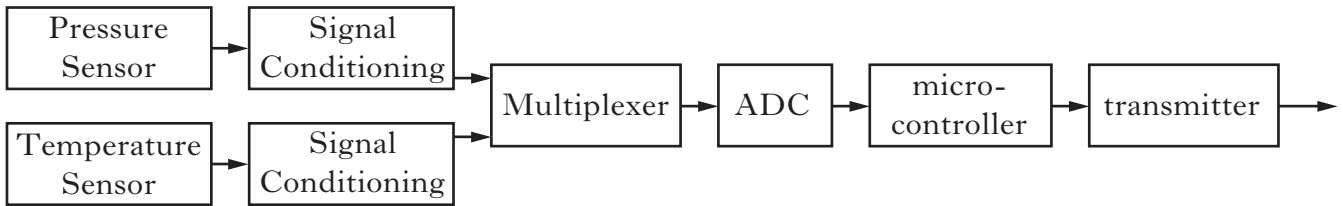

Figure Q10(a)

The pressure sensor produces an output of 140 mV per N/mm². The 8-bit analogue-digital converter (ADC) has a reference voltage of 4.8 V.

- (a) (i) Design a signal-conditioning circuit based on a single op-amp that will produce an output of 3.2 V at a pressure of 0.7 N/mm². 5
- (ii) Calculate the output of the ADC as a binary value when the tyre pressure is 0.56 N/mm². 5

The flowchart shown in Figure Q10(b) represents the sub-procedure *tyrewarn*, used by the microcontroller to monitor the tyre pressure and temperature.

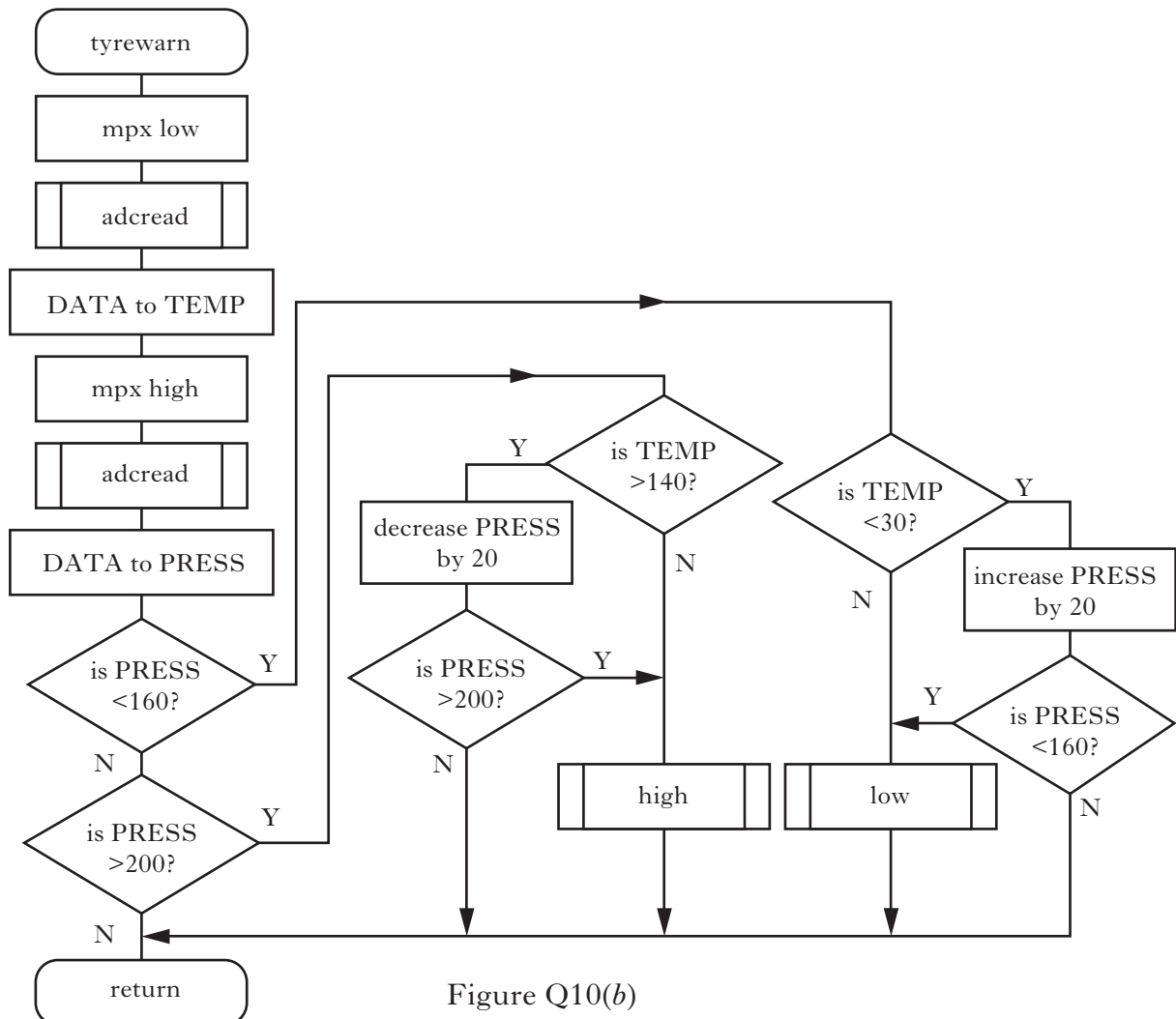

Figure Q10(b)

10. (continued)

The pre-written sub-procedure *adcread* reads a value from the ADC and stores it in the variable DATA. The value held in DATA is transferred into the variable TEMP (for temperature), or into the variable PRESS (for pressure), depending on the logic state of the multiplexer (mpx), which is connected to pin 4 of the microcontroller.

(b) Write, in PBASIC, the sub-procedure *tyrewarn*.

18

The two dashboard warning lamps are controlled by the circuit shown in Figure Q10(c).

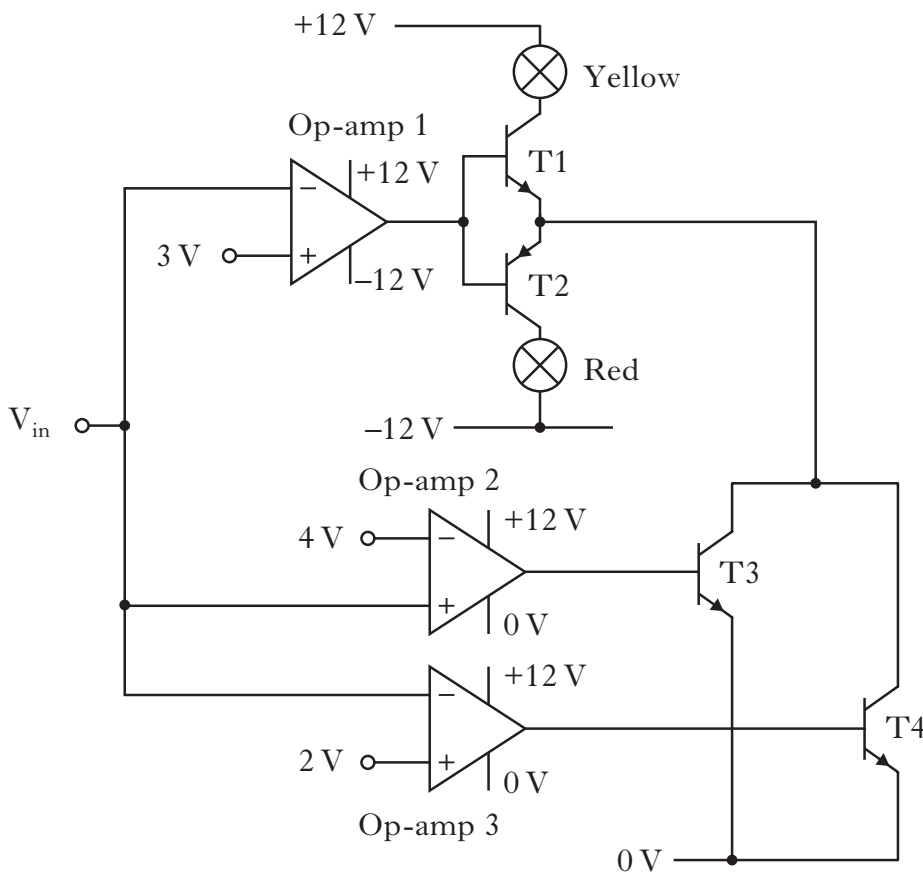

Figure Q10(c)

(c) Describe in detail how the circuit responds as V_{in} increases from 0 V to 5 V.

8

In an alternative circuit developed to operate the dashboard warning lamps, all three op-amps in Figure Q10(c) were replaced by a single difference amplifier. T3 and T4 were found to be redundant.

(d) Sketch an arrangement for the modified circuit, showing all relevant resistor values.

4

(40)

11. The concert spotlight shown in Figure Q11(a) is moved through an arc by a stepper motor controlled by a microcontroller. Marks



Figure Q11(a)

- (a) State **two** advantages of using a stepper motor rather than a DC motor in this application. 2

A sub-procedure *crowdspot* moves the spotlight in an arc to illuminate the audience when the sound level reaches a predetermined value. The sound level is sampled and processed by an ADC. A pre-written sub-procedure *adcread* reads the binary value of the sound level and stores it in the variable DATA. The value in DATA is tested and if it is greater than 182 then the spotlight moves as follows: the stepper motor rotates through an arc of 144° in 4 seconds, pauses for 1.5 seconds and then returns to its start position in 1.6 seconds. The stepper motor turns 1.8° per step.

The step sequence for the stepper motor is shown in Figure Q11(b).

Step	Pins			
	7	6	5	4
1	1	0	1	0
2	1	0	0	1
3	0	1	0	1
4	0	1	1	0

Figure Q11(b)

- (b) Write, in PBASIC, the sub-procedure *crowdspot*. 15

The spotlight is supported by the bracket shown in Figure Q11(c). Two mild-steel bolts, of initial length 120 mm, support the bracket and are in tension.

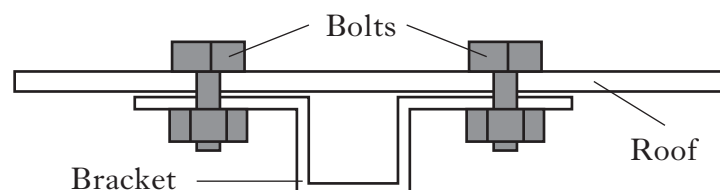

Figure Q11(c)

11. (continued)

Each bolt carries a tensile force of 50 N due to tightening, and a factor of safety of 10 is applied. The weight of the spotlight is 330 N.

- (c) (i) Calculate the maximum permitted extension of each bolt. 7
 (ii) Calculate the minimum required diameter for each bolt. 6

The brightness of the spotlight can be altered by varying the voltage output from a microcontroller.

Pins 5, 6 and 7 control a summing amplifier configured as a digital-analogue converter (DAC).

The microcontroller output pins are 6 V when high.

The required outputs from the DAC are shown in Figure Q11(d).

The output driver for the spotlight is a MOSFET transistor.

Logic level of microcontroller pins			DAC output (V)
7	6	5	
0	0	1	1.5
0	1	0	3.0
1	0	0	6.0

Figure Q11(d)

Worksheet Q11(d) shows an incomplete circuit for a DAC.

- (d) On **Worksheet Q11(d)** complete the circuit (within the dashed box) to control the output of the spotlight. Calculate suitable resistor values and show all connections. 5

The MOSFET has a threshold voltage (V_T) of 1.75 V and a transconductance of 10 A/V (amps/volt). I_{DS} saturates at 10 A.

- (e) On **Worksheet Q11(e)** draw a graph showing I_{DS} against V_{GS} . 5
(40)

[END OF QUESTION PAPER]

ACKNOWLEDGEMENTS

Question 7 – 91426052 Shutterstock.com

Question 11 – 133113059 Christian Bertrand/Shutterstock.com

FOR OFFICIAL USE

--	--	--	--	--	--

Marks

--

X036/12/11

NATIONAL
QUALIFICATIONS
2014

THURSDAY, 15 MAY
1.00 PM – 4.00 PM

TECHNOLOGICAL
STUDIES

HIGHER

Worksheets for Q11(d) and Q11(e)

Fill in these boxes and read what is printed below.

Full name of centre

--

Town

--

Forename(s)

--

Surname

--

Date of birth

Day Month Year

--	--	--	--	--	--

Scottish candidate number

--	--	--	--	--	--	--	--	--	--

Number of seat

--

To be inserted inside the front cover of the candidate's answer book and returned with it.



WORKSHEET Q11(d)

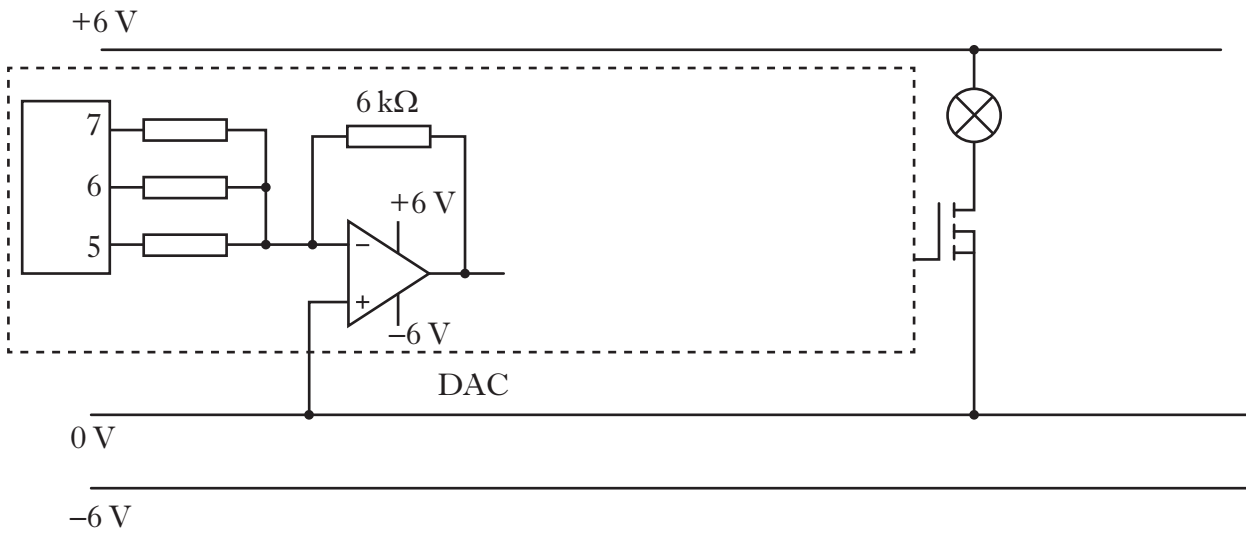

WORKSHEET Q11(e)

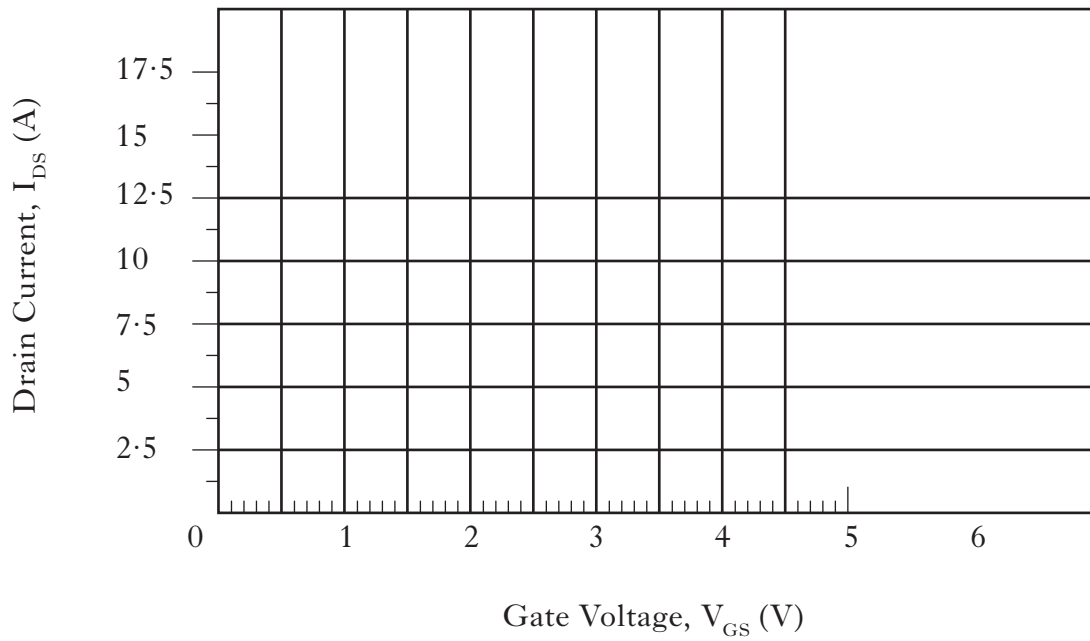

[END OF WORKSHEET]