

# X036/13/01

---

NATIONAL  
QUALIFICATIONS  
2013

TUESDAY, 21 MAY  
1.00 PM – 4.00 PM

TECHNOLOGICAL  
STUDIES  
ADVANCED HIGHER

200 marks are allocated to this paper.

Answer **all** questions in Section A (120 marks).

Answer **two** questions from Section B (40 marks each).

Where appropriate, you may use sketches to illustrate your answer.

You should plan assembler code programs using a flowchart or other suitable method.

Reference should be made to the Advanced Higher Data Booklet (2008 edition) which is provided.



SECTION A

Attempt ALL the questions in this Section. (Total 120 marks)

1. A digestion reactor used in the production of bio-gas is shown in Figure Q1. The temperature of the heated pulp may be varied during the process. The thermal energy input is adjusted using a closed-loop PID control system.

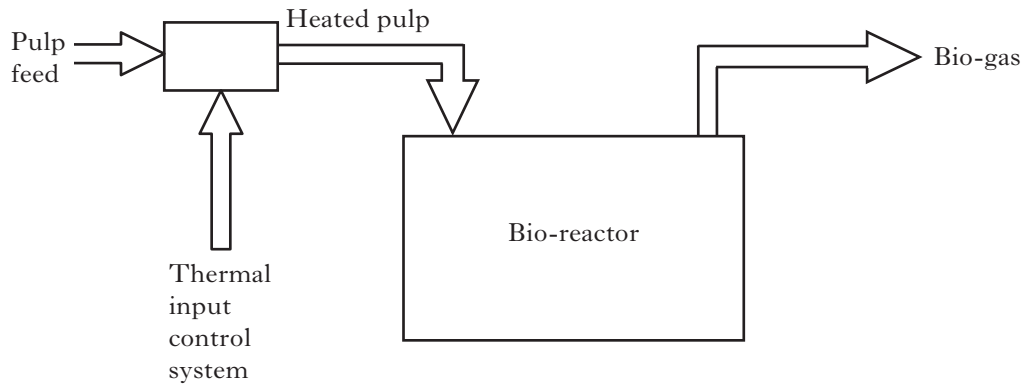

Figure Q1

During operation of the reactor the desired pulp temperature is changed from 50 °C to 70 °C as shown on **Worksheet Q1**.

- (a) On **Worksheet Q1**, complete the temperature-time graphs for the following conditions:
    - (i) **Proportional only**: gain factor set **too low**; 2
    - (ii) **Proportional only**: gain factor set **too high**; 2
    - (iii) Full **Proportional, Integral and Derivative** (PID) control. 2
  - (b) Explain the reason for adding **Integral** control to the proportional control system. 2
  - (c) Explain the reason for adding **Derivative** control to the proportional control system. 2
- (10)**

2. The cross-section of a rail is shown in Figure Q2(a). Details of the two “y” values about its neutral axis are also indicated.

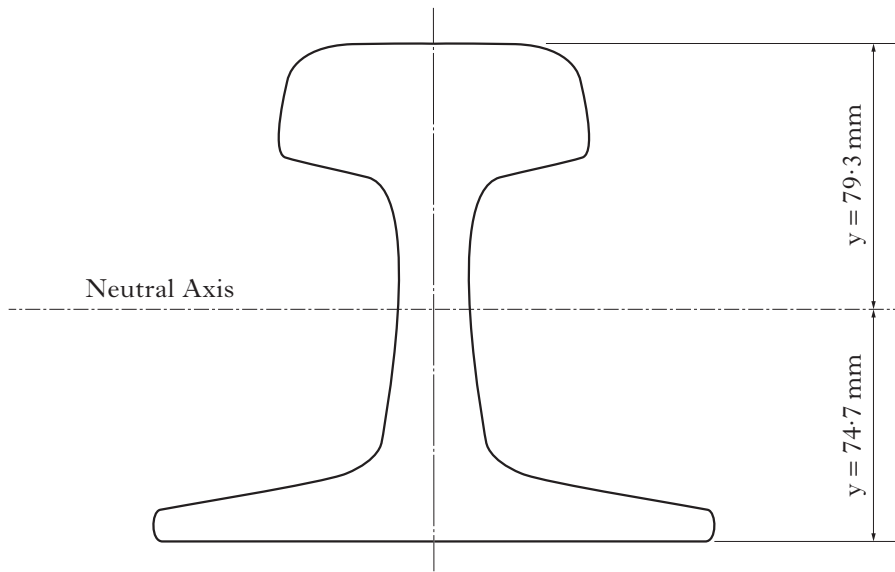

Figure Q2(a)

- (a) State the reason for the two different “y” values shown in Figure Q2(a).

1

Part of the rail, which is supported by railway sleepers, is shown in Figure Q2(b). The rail is loaded by the wheel of a train.

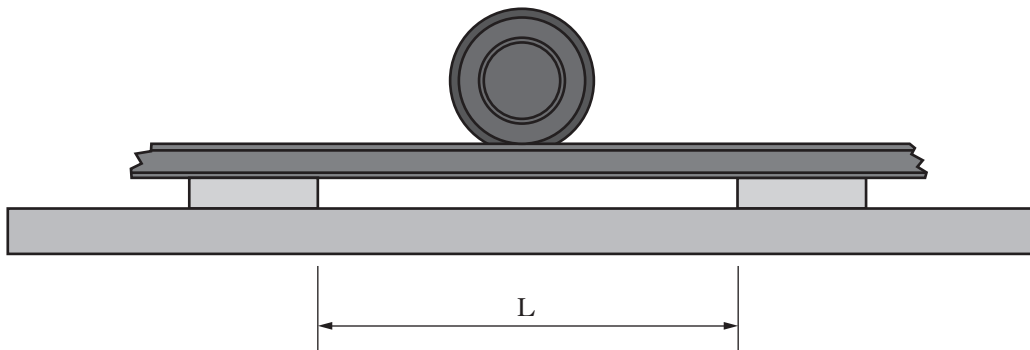

Figure Q2(b)

The rail can be considered to be a beam with built-in ends and a central point load of 180 kN. The Second Moment of Area about the Neutral Axis is  $20.1 \times 10^6 \text{ mm}^4$ . The maximum tensile stress due to bending is not to exceed  $150 \text{ N/mm}^2$ .

- (b) Determine the maximum allowable span “L” between the sleepers.

7

Young’s Modulus for the rail material is  $200 \text{ kN/mm}^2$ .

- (c) Calculate the radius of curvature of the loaded rail.

3

(11)

[Turn over

3. Figure Q3(a) shows a competitor attempting to manoeuvre a kayak between the poles of a “gate” during a river-slalom competition. The lower ends of the poles should be at a particular height above the surface of the water, whatever the actual level of water in the river.



Figure Q3(a)

The competition organisers have commissioned an automatic system that can vary the height of the gates, in order to cope with fluctuations in water level during the competition. The proposed microcontroller-controlled system is shown in Figure Q3(b).

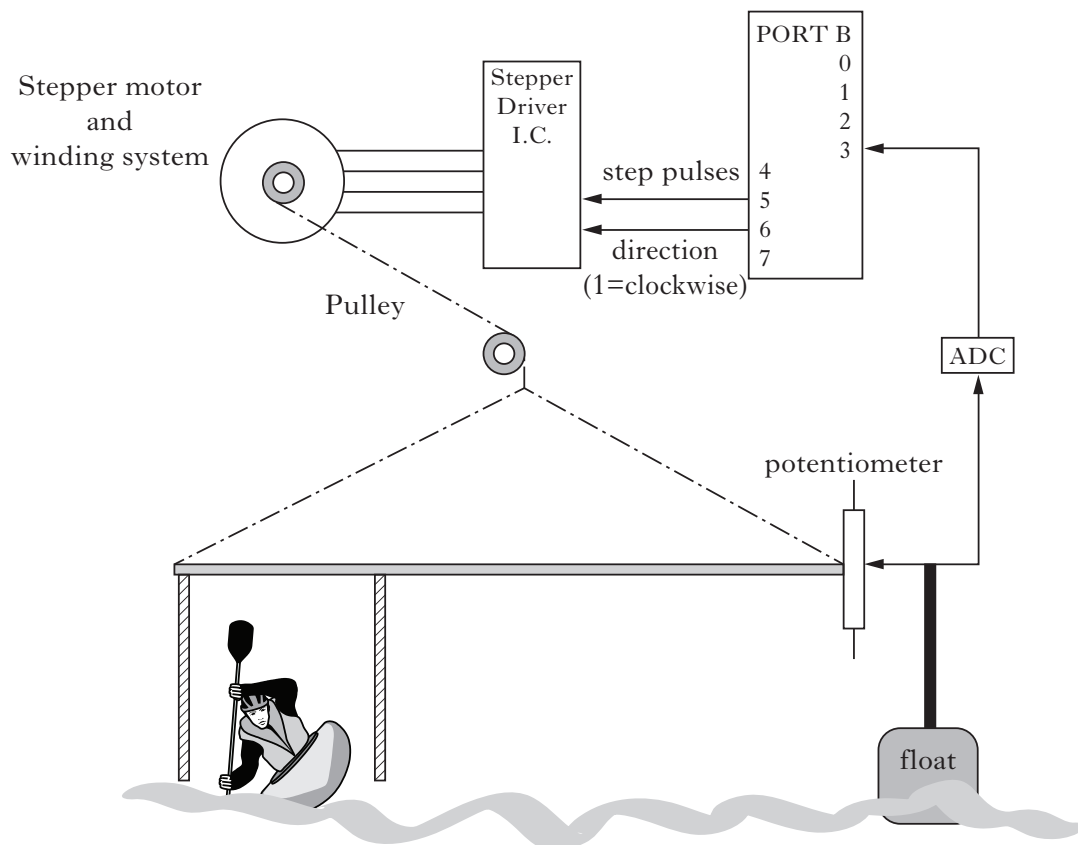

Figure Q3(b)

The potentiometer body is fixed to the gate. As the river level varies, the float moves the wiper of the potentiometer via a pushrod, which produces an analogue signal proportional to the river level. The microcontroller monitors this via an Analogue-to-Digital Converter (ADC), and raises or lowers the gates via a stepper motor and winding system, as required to maintain the correct gap between poles and water.

3. (continued)

The control program works as follows:

A sub-procedure *adcread* is called, which stores the potentiometer reading in a register file DATA.

If DATA = 128 then no action is taken.

If DATA > 128 then sub-procedure *raise* is called.

If DATA < 128 then sub-procedure *lower* is called.

The program repeats continuously.

(a) Write, in assembler code, the control program.

10

**Note:** The register file DATA has been set up and TRISB has been initialised.

The sub-procedure *raise* works as follows:

The stepper-motor driver is set to rotate clockwise.

The stepper motor is rotated for 4 steps in a loop.

The pulse-cycle time is 20 s, with an ‘on’ time of 0.1 s.

The sub-procedure ends.

(b) Write, in assembler code, the sub-procedure *raise*.

11

(21)

**Note:** The sub-procedure *wait* creates a delay of 100 ms multiplied by the value in the Working Register, W, before the procedure is called. The register file COUNTER has been set up.

4. A countdown timer is shown in Figure Q4. It provides a visual display running from 59 to 0 so that a number of tasks performed in less than a minute can be assessed.

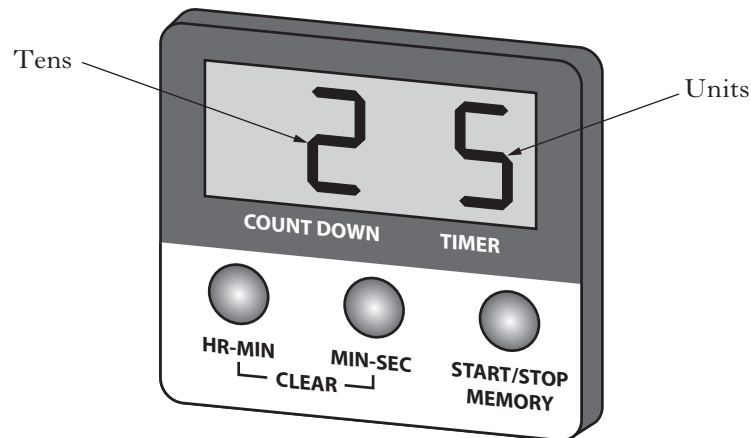

Figure Q4

The counter circuit is constructed from J-K bistables. The “units” counter is clocked directly by a 1 Hz clock signal, which is divided by 10 for the “tens” counter clock signal. The “tens” counter is preset to 5, the “units” counter to 9, and the display shows a real-time count. When the counter reaches 00 a buzzer sounds, and the display freezes.

**Worksheet Q4** shows an incomplete circuit diagram for the system.

On **Worksheet Q4** complete the circuit diagram for the counter.

13

(13)

5. A student is experimenting with serial transfer for data logging using a microcontroller. The basic principle uses the **Carry Bit** of the Status Register to read an 8-bit value into a register file as shown in Figure Q5.

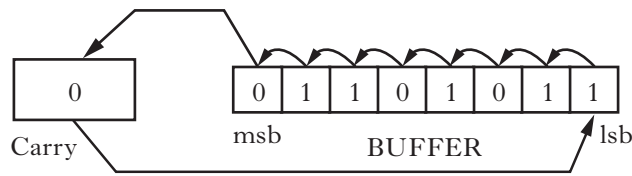

Figure Q5

One method the student tries uses a sub-procedure *read* to save an 8-bit value into the register file BUFFER. Sub-procedure *read* works in the following way.

First the carry bit is cleared. Pin 3 is then checked every 3 ms in an 8-times repeat loop. If pin 3 is high when it is checked, the carry bit is set; if pin 3 is low the carry bit is cleared. The register file BUFFER is rotated one place to the left. When the 8-bit value has been saved into BUFFER this is indicated by an LED connected to pin 7 flashing 4 times in a loop at a frequency of 2 Hz (on for 0.25 s off for 0.25 s).

The input/output connections are shown in the table below.

Input connections	PORTB pins	Output connections
	7	LED
	6	
	5	
	4	
Data input	3	
	2	
	1	
	0	

Write, in assembler code, the sub-procedure *read*.

18  
(18)

**Note:** The sub-procedure *pause* creates a delay of 1 ms multiplied by the value in the Working Register, W, before the procedure is called. The register files COUNTER and BUFFER have been set up and TRISB has been initialised.

6. A sequential control system is under development for the toy robot dog shown in Figure Q6.



Figure Q6

The toy will have the following features:

- an LED in each eye;
- a motor to wag the tail;
- a motor to make it walk;
- a solenoid to make it flip;
- a sound generator to make it bark.

The electronic circuit shown on **Worksheet Q6** represents a simulation used to test the sequential control of the toy.

- |   |             |
|---|-------------|
| (a) Explain the operation of the toy in terms of sub-systems A–E.                       | 8           |
| (b) Complete, on <b>Worksheet Q6</b> , the table for the sequential control of the toy. | 7           |
|   | <b>(15)</b> |

[Turn over

7. Carbon-Fibre-Reinforced Polymer is used to strengthen and prolong the life of structural concrete beams. Figure Q7 shows the free-body diagram for a test of one such beam.

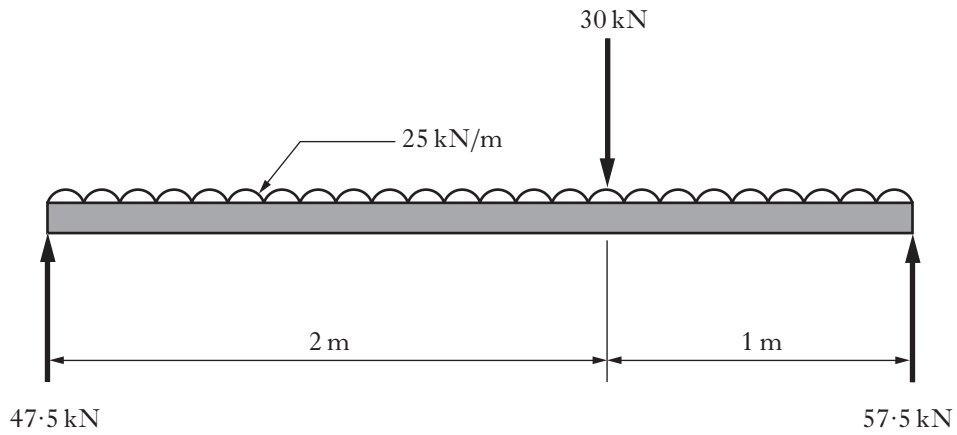

Figure Q7

- (a) (i) Sketch the shear-force diagram, showing values at all significant points. 4  
 (ii) Determine the position of the maximum bending-moment from the left-hand end. 2

- (b) Copy and complete the table shown below.

Show all working.

<b>Distance from left hand end (m)</b>	<b>0</b>	<b>0.5</b>	<b>1</b>	<b>1.5</b>	<b>2</b>	<b>2.5</b>	<b>3</b>
<b>Bending moment (kNm)</b>							

12  
(18)



8. An electronic control circuit, to be used for a charity quiz game, is to be constructed by a group of school pupils.

The system will allow for three contestants, A, B and C, and a quiz master.



One proposed circuit for the control of the quiz game is shown on **Information Sheet Q8**; a pin-out diagram for the 555 I.C. contained in the circuit is shown in Figure Q8 below.

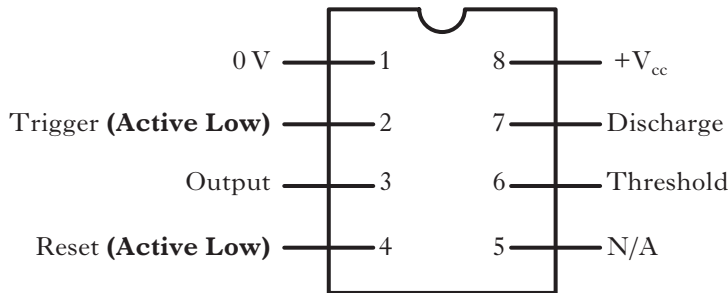

Figure Q8

- (a) Explain the operation of the circuit in terms of all 5 sub-systems shown on **Information Sheet Q8**.

11

- (b) Calculate the frequency of the signal sent to the loudspeaker.

3

(14)

[END OF SECTION A]

[Turn over

SECTION B

Attempt any TWO questions in this Section.

Each question is worth 40 marks

9. The motorised treadmill shown in Figure Q9 is controlled by a microcontroller using Pulse Width Modulation. The distance run is obtained from the conveyor belt using a digital sensor, and is displayed on the console.



Figure Q9

The main control sequence is as follows.

When the start switch is pressed, the motor runs at a predetermined speed defined by the initial values held in the register files MARK and SPACE. When a speed-increase button is pressed the value in MARK is increased by 2. When a speed-decrease button is pressed the value in MARK is decreased by 2. Each time the input from the digital sensor goes high the register file COUNT is incremented. Then the COUNT value is multiplied by 4 and saved into the Working Register (W). To display the distance covered by the runner, pin 6 is set high for the time in ms represented by the value in the Working Register. The program repeats until the stop switch goes high.

Input connections	PORTB pins	Output connections
	7	Motor
	6	Distance display sub-system
Stop switch	5	
Speed-increase button	4	
Speed-decrease button	3	
	2	
Start switch	1	
Digital sensor	0	

- (a) Write, in assembler code, the main program to carry out the function described above.

24

**Note:** The sub-procedure *pause* creates a delay of 1 ms multiplied by the value in the Working Register, W, before the procedure is called. The required register files have been set up and TRISB has been initialised.

**9. (continued)**

Pin 6 has a signal value of +6 V when high and is connected to the input of an integrator sub-system: the longer pin 6 is high the larger the output from the sub-system.

The integrator sub-system must produce an output of +8 V after 0.2 seconds, using a capacitor value, C, of 47  $\mu\text{F}$ .

- (b) (i) Calculate the required value of resistor R. 6
- (ii) Sketch the integrator sub-system. 2

The output from the integrator sub-system is fed into an Analogue-to-Digital Converter (ADC) which controls the distance display. The Digital-to-Analogue Converter (DAC) part of the ADC has digital inputs of 6 V.

- (c) Design an 8-bit DAC, using a feedback resistor of 15 k $\Omega$ , which will produce an output in the range of 0–9 V. (Show all resistor values.) 8
- (40)**

**[Turn over**

10. The robot arm shown in Figure Q10(a) is used to transfer cargo from a pick-up point onto a conveyor belt.



Figure Q10(a)

The arm is driven by a 4-coil stepper motor, as shown in Figure Q10(b).

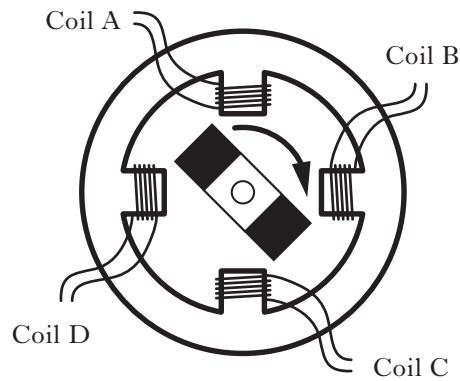

Figure Q10(b)

To prevent mechanical damage to the cargo as it approaches its desired position, the arm is equipped with a proximity sensor which initiates a slow-down procedure (soft-stop) on the stepper-motor.

The control circuit for the stepper-motor clock pulse is shown on **Information Sheet Q10**.

The resistance of the proximity sensor increases as the arm approaches the conveyor belt.

- (a) Explain the operation of the circuit shown on **Information Sheet Q10** in terms of sub-systems A and B.

10. (continued)

Marks

Sub-system A is constructed from the Schmitt Trigger shown in Figure Q10(c).

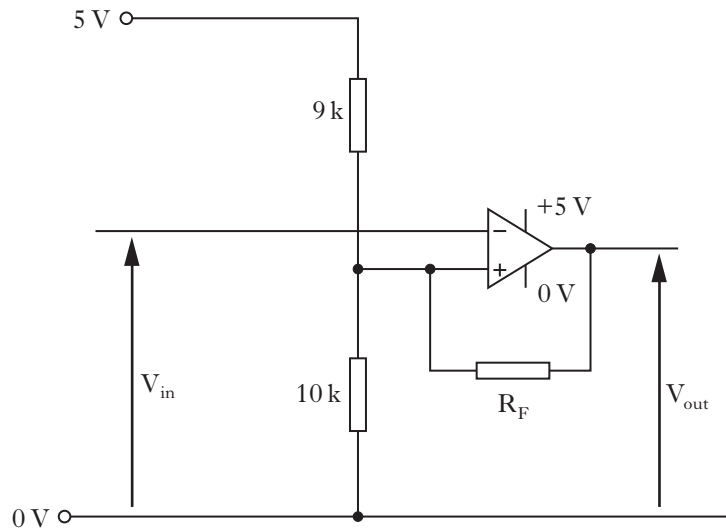

Figure Q10(c)

The switch-off threshold voltage is 3.5 V.

- (b) Calculate the required value of the feedback resistor  $R_F$ .

8

Clock pulses are fed into sub-system B on **Information Sheet Q10**. An incomplete timing diagram for the coils is shown on **Worksheet Q10**.

- (c) Complete the timing diagram shown on **Worksheet Q10**.

8

One arm of the robot is 1 m in length and is constructed from a hollow square cross-section as shown in Figure Q10(d).

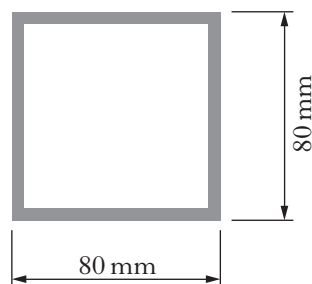

Figure Q10(d)

The arm is mild steel and can be considered to be a **cantilever beam** with a point load of 2 kN acting at its free end. The outside dimension of the cross-section is 80 mm, and the maximum allowable stress due to bending is 100 N/mm<sup>2</sup>.

Calculate:

- (d) (i) the minimum required wall thickness of the cross-section;  
 (ii) the deflection of the beam.

12

4

(40)

11. A radio-receiver dish mounted on a tower, as shown in Figure Q11(a), monitors the airwaves for a distress signal, which consists of the three letters “S O S”. A microcontroller is used to process the received signals.

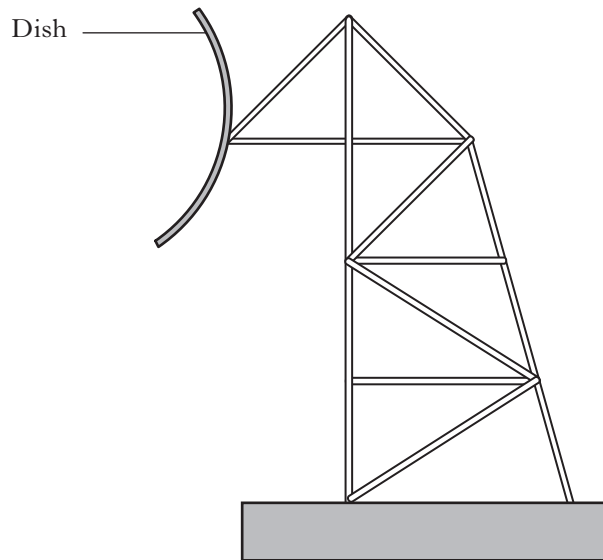

Figure Q11(a)

The “S O S” serial digital signal is transmitted using Morse Code, which consists of “dots” and “dashes”. The time duration of a signal pulse determines whether the letter is a dot or a dash. The letter **S** is represented by three consecutive dots and the letter **O** by three consecutive dashes.

The main microcontroller program uses two sub-procedures, *S\_Test* and *O\_Test* and operates as follows:

- The register file DISTRESS is cleared
- Sub-procedure *S\_Test* is called
- Sub-procedure *O\_Test* is called
- Sub-procedure *S\_Test* is called again
- If the value in DISTRESS is equal to 3, then a lamp connected to PORTB pin 5 is lit
- The program ends

- (a) Write, in assembler code, a program to fulfil this function.

8

**Note:** The register file DISTRESS is set up and TRISB is initialised.

The signal from the satellite dish is fed into PORTB pin 0. The sub-procedure *S\_Test* monitors for a morse-code **S** and operates as follows:

- The following sequence is carried out three times in a loop:
  - PORTB pin 0 is monitored until it goes high;
  - There is a 100-millisecond delay;
  - If PORTB pin 0 is low then the register file DOTCOUNT is incremented.
- After three loops of the above, DOTCOUNT is checked.
- If DOTCOUNT is equal to 3, DISTRESS is incremented and the sub-procedure ends.
- If DOTCOUNT is not equal to 3, DISTRESS is not incremented and the sub-procedure ends.

- (b) Write, in assembler code, the sub-procedure *S\_Test*.

14

**Note:** The sub-procedure *wait* creates a delay of 100 ms multiplied by the value in the Working Register, W, before the procedure is called. The register files COUNTER and DOTCOUNT have been set up.

11. (continued)

Marks

The tower is loaded by the weight of the dish and a wind force as shown in Figure Q11(b).

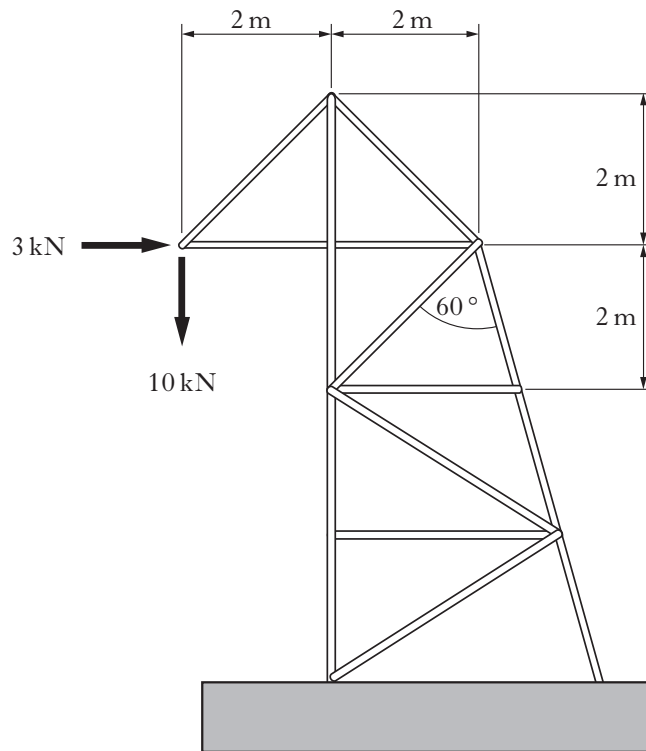

Figure Q11(b)

A section of the upper part of the tower is shown in Figure Q11(c).

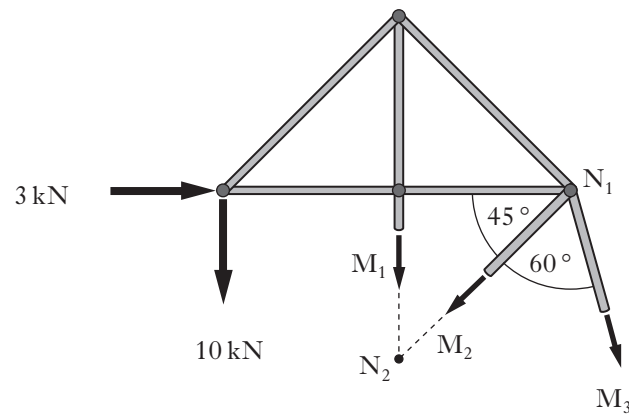

Figure Q11(c)

- (c) Calculate, using the *method of sections*, the **magnitude** and **nature** of the forces acting in  $M_1$ ,  $M_2$  and  $M_3$ .

18  
(40)

[END OF QUESTION PAPER]

**[BLANK PAGE]**



FOR OFFICIAL USE

--	--	--	--	--	--

## X036/13/11

NATIONAL  
QUALIFICATIONS  
2013

TUESDAY, 21 MAY  
1.00 PM – 4.00 PM

TECHNOLOGICAL  
STUDIES  
ADVANCED HIGHER  
Worksheets for Questions 1,  
4, 6 and 10  
Information Sheets for  
Questions 8 and 10

Fill in these boxes and read what is printed below.

Full name of centre

Town

Forename(s)

Surname

Date of birth

Day    Month    Year

--	--	--	--	--	--

Scottish candidate number

--	--	--	--	--	--	--	--	--	--

Number of seat

To be inserted inside the front cover of the candidate's answer booklet and returned with it.



**WORKSHEET Q1**

(a) (i)

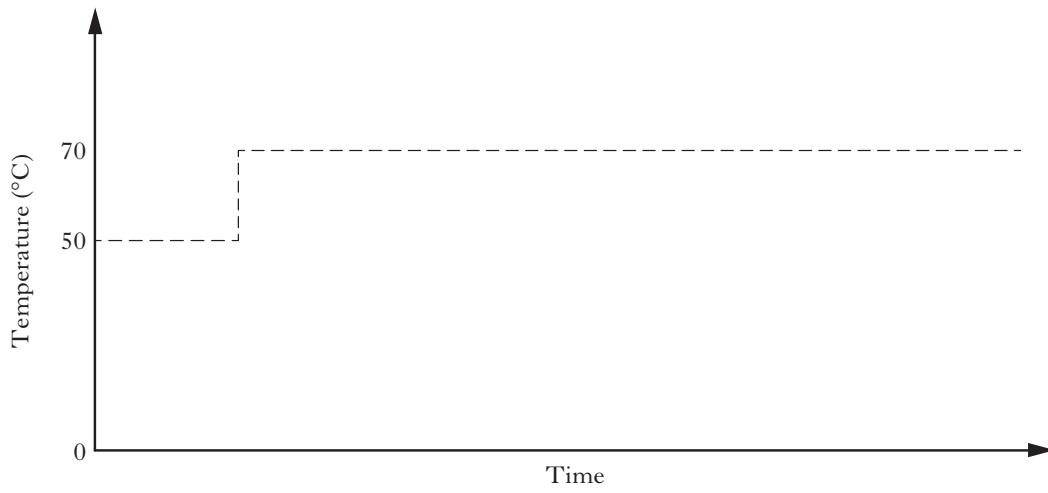

(ii)

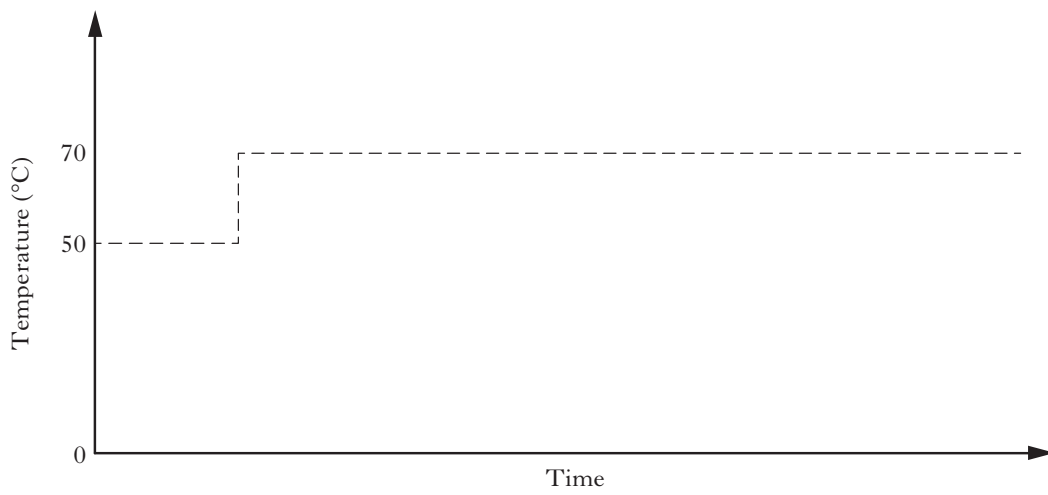

(iii)

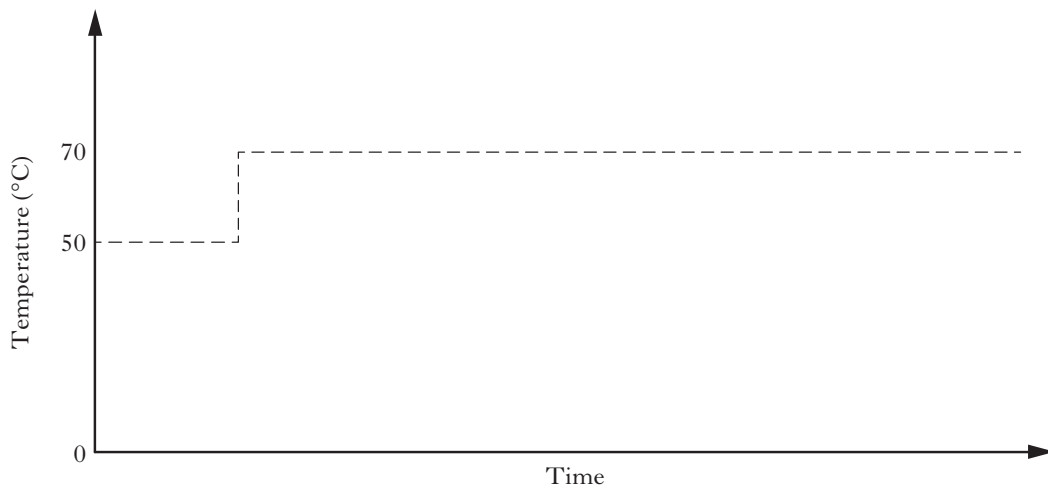

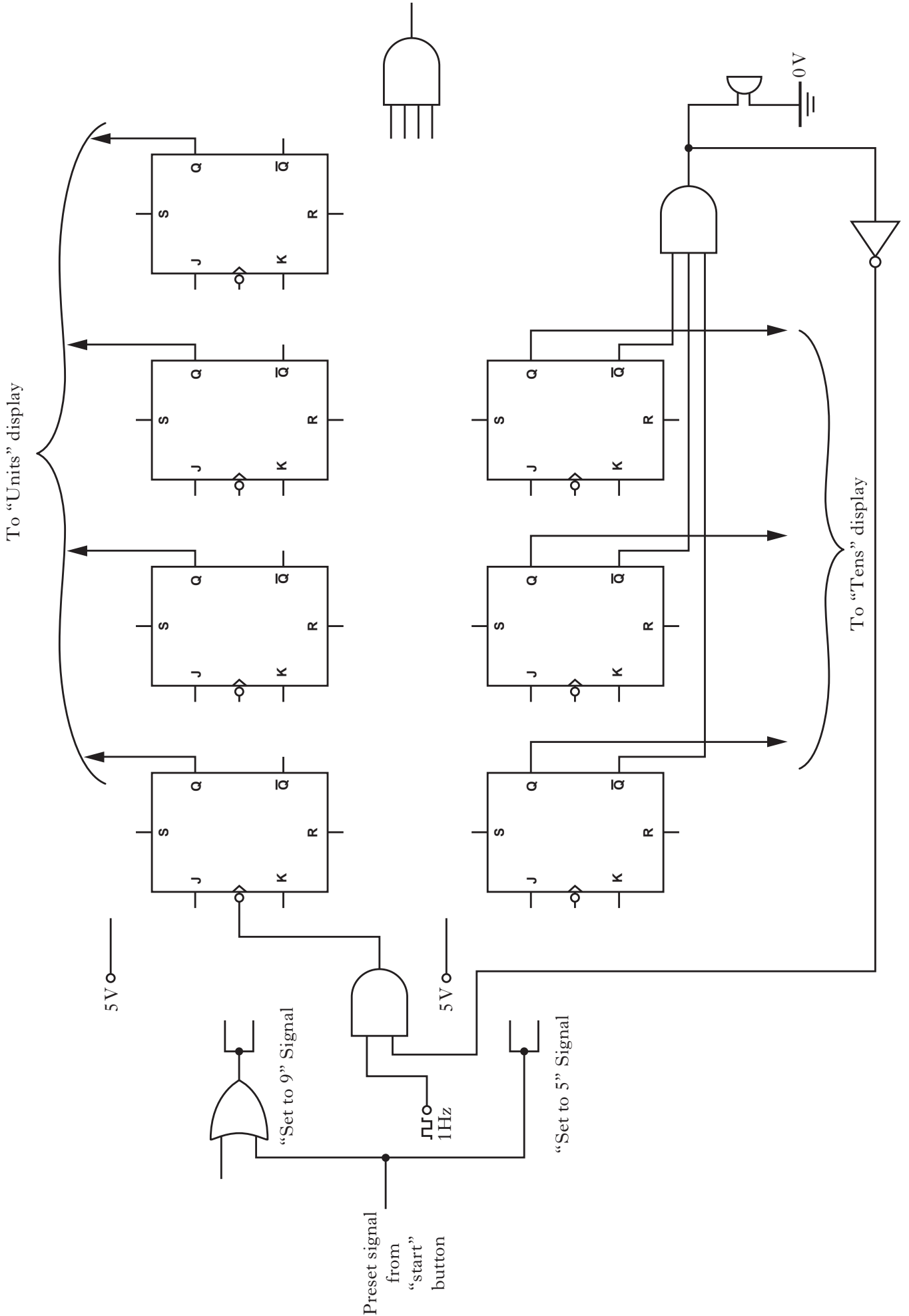

WORKSHEET Q6

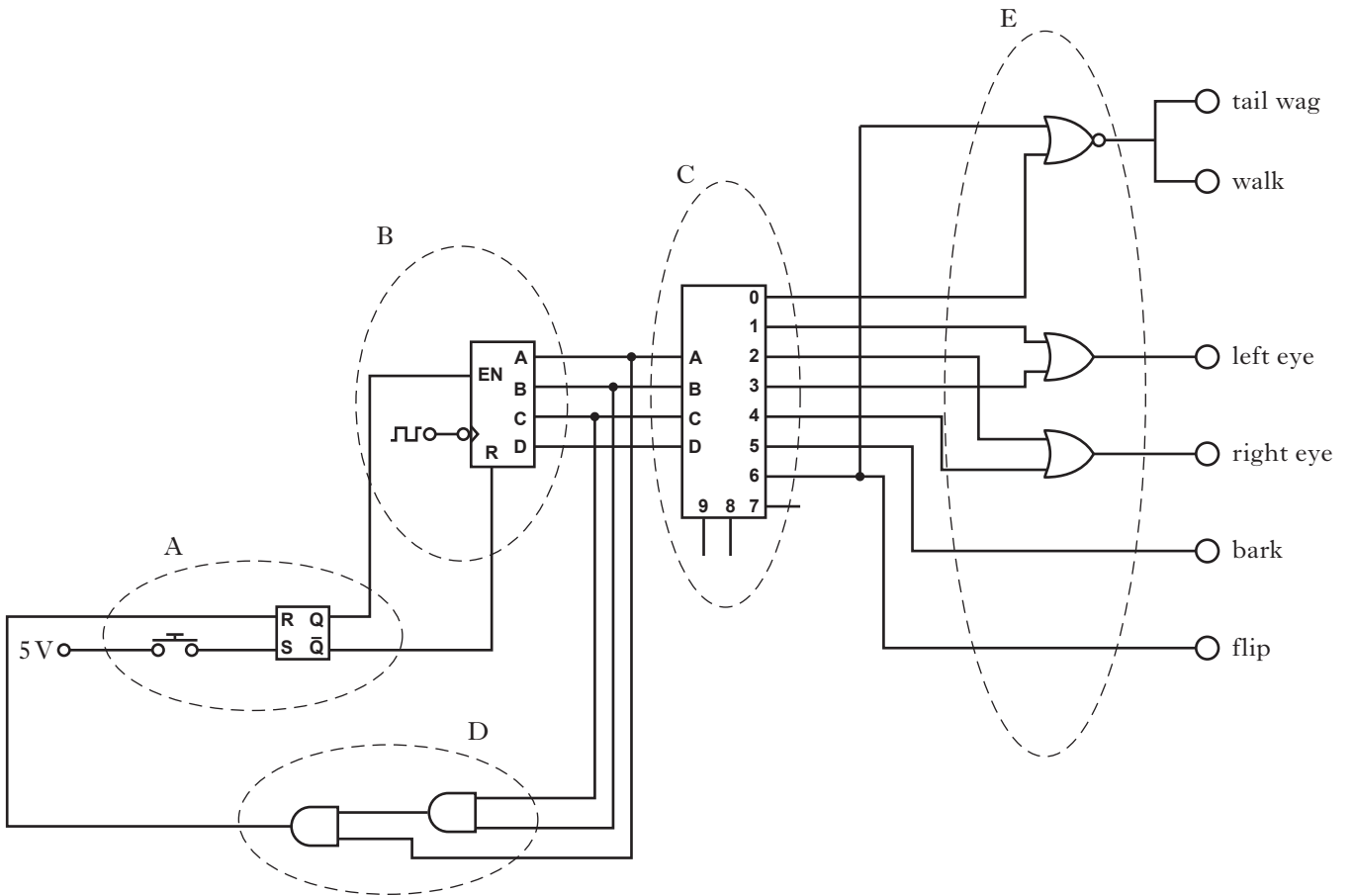

Counter Count	Tail Wag	Walk	Left Eye	Right Eye	Bark	Flip
0						
1						
2						
3						
4						
5						
6						
7						

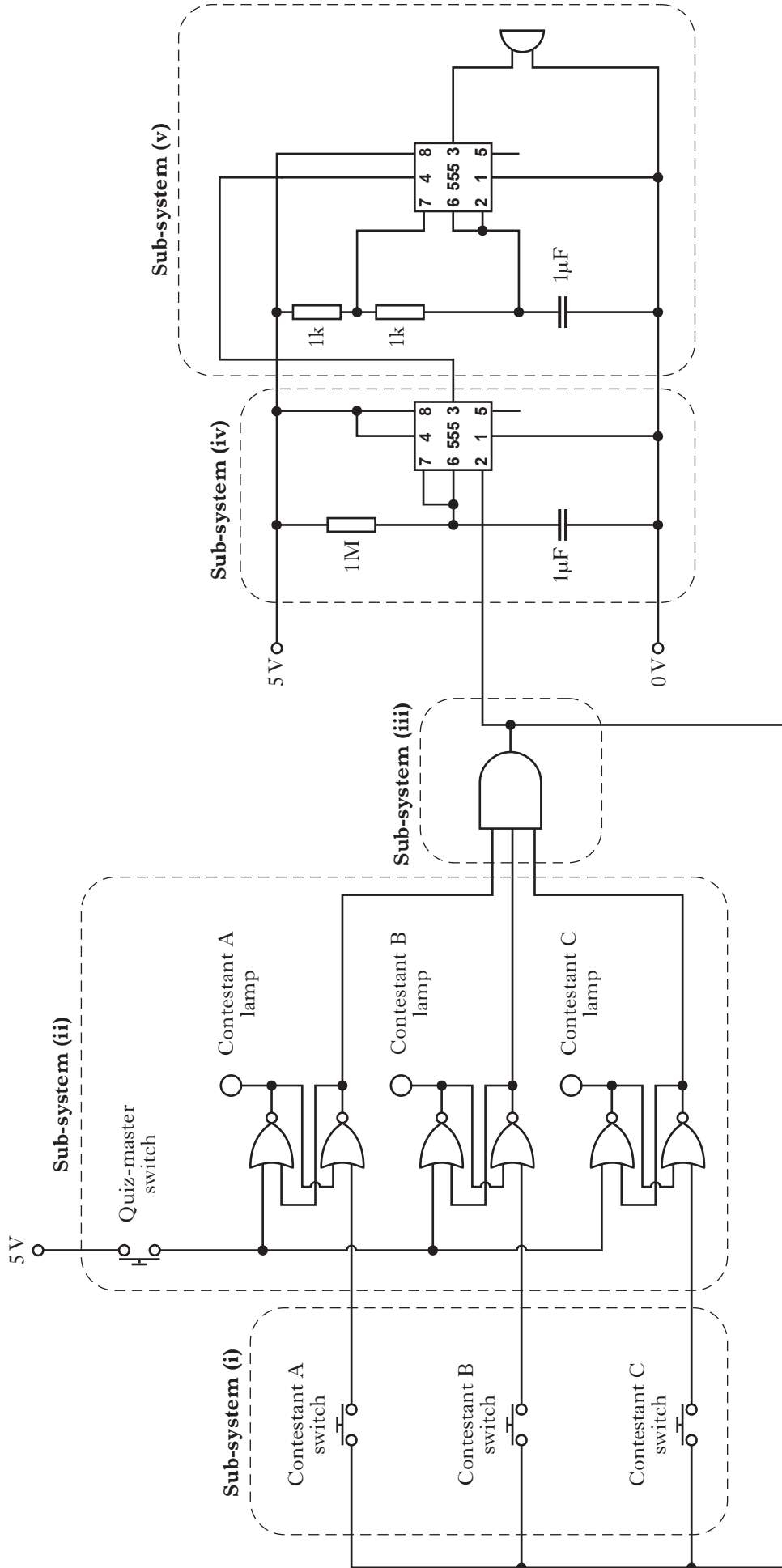

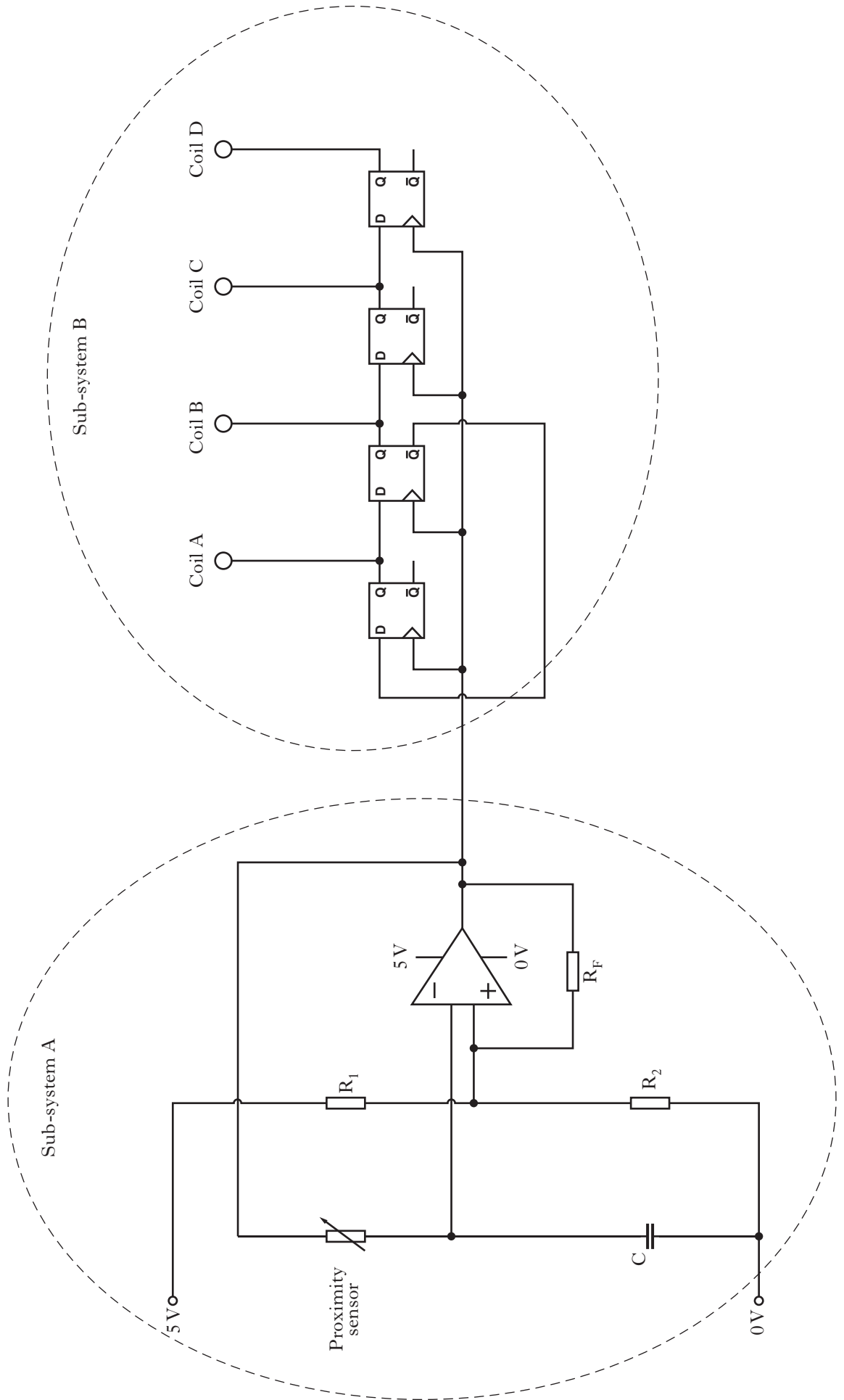

WORKSHEET Q10

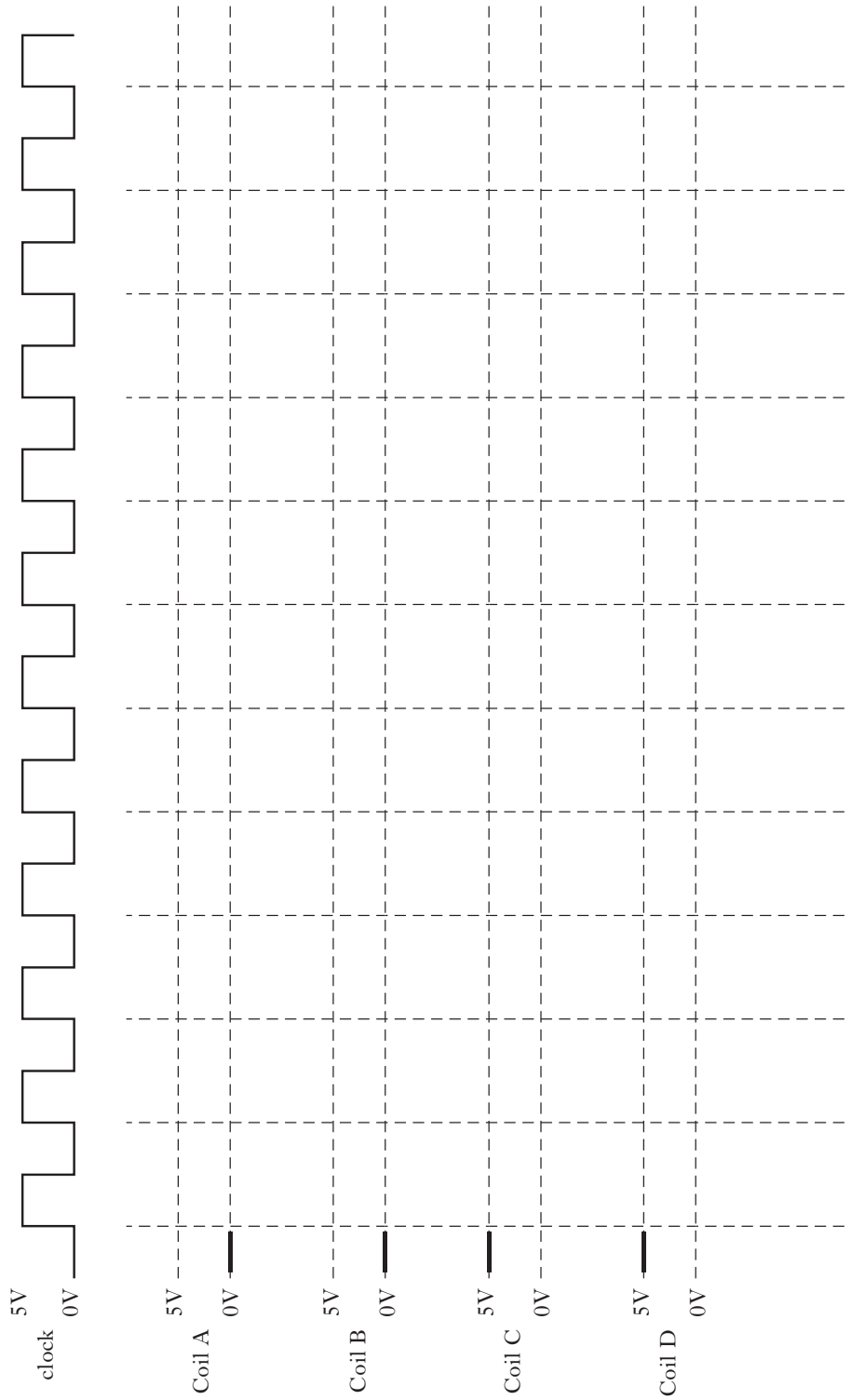

[END OF WORKSHEETS]

**[BLANK PAGE]**