

X036/701

NATIONAL
QUALIFICATIONS
2011

FRIDAY, 27 MAY
9.00 AM – 12.00 NOON

TECHNOLOGICAL
STUDIES
ADVANCED HIGHER

100 marks are allocated to this paper.

Answer **all** questions in Section A (60 marks).

Answer **two** questions from Section B (20 marks each).

Where appropriate, you may use sketches to illustrate your answer.

You should plan assembler code programs using a flowchart or other suitable method.

Reference should be made to the Advanced Higher Data Booklet (2008 edition) which is provided.



SECTION A

Attempt ALL the questions in this Section. (Total 60 marks)

1. The electronic device shown in Figure Q1 illuminates LEDs in order to represent a number between **one** and **six**.

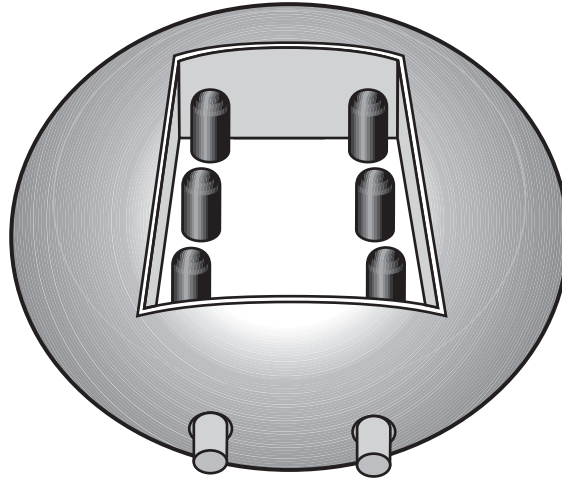

Figure Q1

The electronic counting circuit is clocked by a 555 timer which has a frequency of 250 Hz, an R_1 value of $2\text{ k}\Omega$ and a C value of $1\ \mu\text{F}$.

- (a) On **Worksheet Q1** draw the circuit for the 555 timer in astable mode. (Show all component values and working.)

3

A partially complete circuit for the electronic device is shown on **Worksheet Q1**.

When the “run” switch is pressed the high outputs from a SIPO shift register increment from one to six and then decrement from six to one continuously, without illuminating the LEDs.

When the “display” switch is pressed, the sequence freezes and the current value is displayed.

- (b) On **Worksheet Q1** complete the circuit for the electronic device.

5

(8)

2. A test-rig for a microcontroller-controlled ejection seat for an aircraft is shown in Figure Q2. It fires the pilot clear of the aircraft in an emergency. An increasing rate of acceleration reduces the risk of pilot injury.

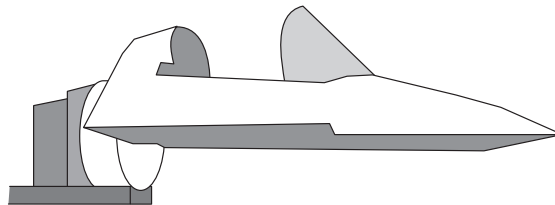

Figure Q2

When the eject handle is pulled, the system works in the following sequence.

- Six sets of propellant charges are activated in sequence. Each propellant charge is activated by a 1 ms pulse.
- The time delay between activations is stored in the register file DELAY, which is initially set to 128 ms.
- DELAY is then halved for each subsequent activation in a six-times repeat loop.
- Further propulsion is then provided by rockets which are fired for 3 seconds to clear the aircraft.
- At speeds above Mach 1.3 the seat also deploys protective netting for pilot retention and windblast protection.
- The pilot-separation handle is then checked every 100 ms in a timed loop for 25 seconds.
- If the pilot pulls the handle during this period the harness is released, otherwise it is assumed the pilot is unconscious and the seat parachute is deployed.

Inputs	PORTB pins	Outputs
	7	Propellant charges
	6	Rockets
	5	Protective netting
	4	Seat parachute
	3	Harness release
Mach 1.3 sensor	2	
Pilot separation handle	1	
Eject handle	0	

Write, in assembler code, a program to carry out the sequence described above.

12

Note: The sub-procedure *pause* creates a delay of 1 ms multiplied by the value in the Working Register W when the procedure is called. The sub-procedure *wait* creates a delay of 100 ms multiplied by the value in W when the procedure is called. The register files DELAY and COUNTER have been set up and TRISB has been initialised.

(12)

3. A student is investigating the op-amp circuit shown in Figure Q3.

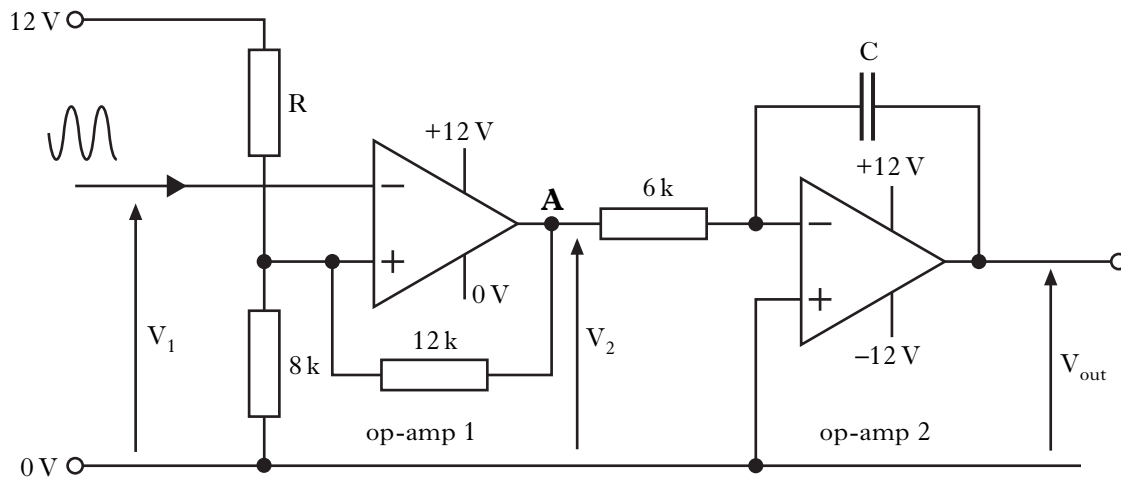

Figure Q3

- (a) State the name of the oscillator which could produce the input voltage V_1 . 1
- (b) Sketch the waveform produced at point A, and explain why this output is used extensively in digital electronic systems. 2

When V_1 falls to 7 V the output of op-amp 1 goes high.

- (c) Calculate the required value of R. 3

When V_2 goes to 12 V, V_{out} is 0 V. After 0.02 seconds the integrating amplifier produces an output voltage V_{out} of -8 V.

- (d) Calculate the required value of capacitor C. 3
- (9)**

4. A company designing adventure-play equipment similar to that shown in Figure Q4(a) produces diagrams showing the effects of loading on the main cross-beam.

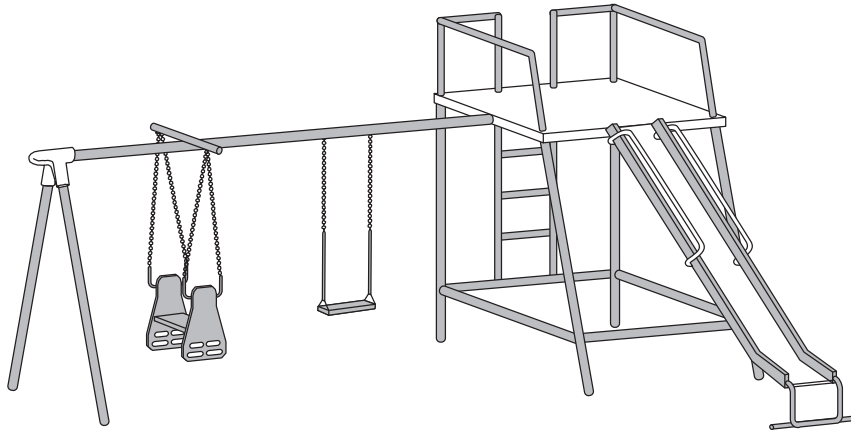

Figure Q4(a)

The loads on the beam due to a ride-on horse and a swing are shown in Figure Q4(b). The self-weight of the beam is also shown.

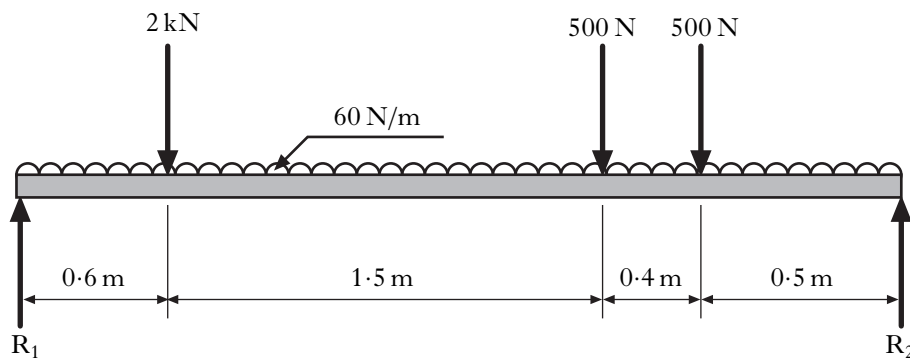

Figure Q4(b)

- (a) Calculate the reactions at R_1 and R_2 . 2
- (b) On **Worksheet Q4**:
- (i) draw the shear-force diagram; 3
- (ii) complete the table of results, showing all working, and draw the bending-moment diagram. 6
- (11)**

[Turn over

5. The firework launcher shown in Figure Q5 is designed to provide a visual countdown to enable the user to retreat to a safe distance.

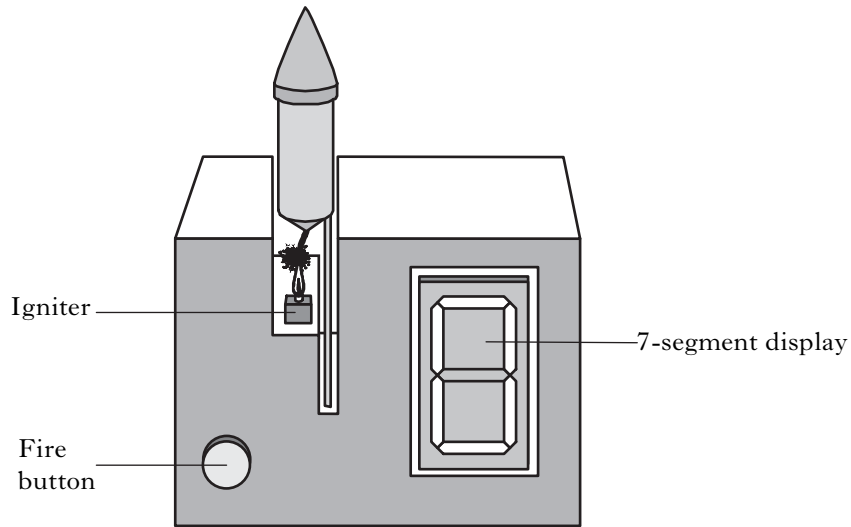

Figure Q5

The launcher circuit is initialised by pressing the fire button. A 4-bit counter presets to 9 and then counts down to zero. The count is displayed on a 7-segment display via a BCD to 7-segment-display decoder. At count zero the igniter is operated using an AND gate, a transistor and a relay. The fire button enables the count, using the SR bistable shown on **Worksheet Q5**.

- (a) On **Worksheet Q5** complete the counting and display circuit.

7

The SR bistable shown on **Worksheet Q5** is constructed using NOR gates.

- (b) Draw a diagram of the required NOR-gate circuit, labelling the input and output lines.

2

(9)

6. The diagram in Figure Q6 shows an injection-moulding machine, used for making plastic components. In order to maintain the plastic within the correct temperature range, the heaters are proportionally controlled using a microcontroller.

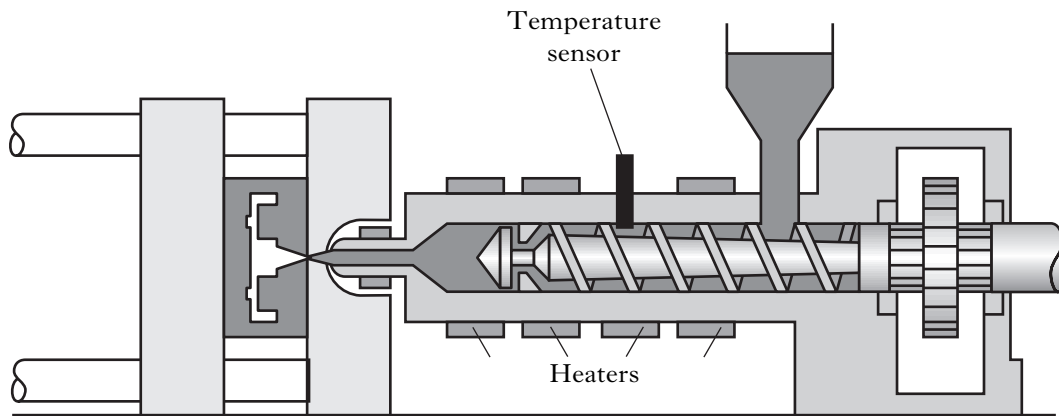

Figure Q6

The proportional control system uses pulse-width modulation to control the heaters. A temperature sensor is connected to the microcontroller via an analogue-to-digital converter (ADC).

The control system works as follows.

- Initially, the mark time (held in the register file MARK) is set to 100 ms and the space time (held in the register file SPACE) is set to 80 ms.
- The temperature in the machine is checked in a loop by calling the sub-procedure *adcread*, which saves the temperature reading into the register file DATA.
- For each repeat of the loop, if the value in DATA is greater than or equal to 160, the error value (DATA-160) is added to SPACE.
- For each repeat of the loop, if the value in DATA is less than or equal to 150, the error value (150-DATA) is added to MARK.
- The heater is turned on for the number of milliseconds held in MARK and off for the number of milliseconds held in SPACE.
- The sequence repeats continuously.

Write, in assembler code, a program to carry out the function described above.

11

Note: The heaters are connected to pin 5 of the microcontroller. The sub-procedure *pause* creates a delay of 1 ms multiplied by the value in the Working Register W when the procedure is called. Sub-procedure *adcread* and register files MARK, SPACE and DATA have been set up. TRISB has been initialised.

(11)

[END OF SECTION A]

[Turn over for SECTION B on Page eight

SECTION B

Attempt any TWO questions in this Section.

Each question is worth 20 marks

7. A car manufacturer is experimenting with the strength and aerodynamic profiles of roofbars for one of its range of cars. Experiments are performed in a wind tunnel as shown in Figure Q7(a).

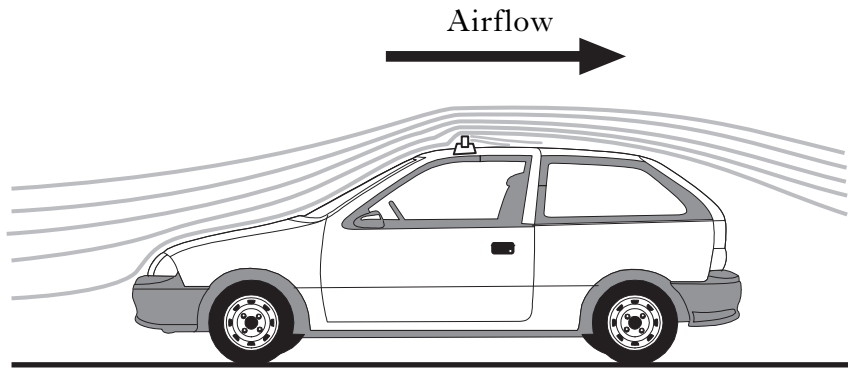

Figure Q7(a)

Several different cross-sectional profiles and orientations for the roofbars are being considered. Two options are shown in Figure Q7(b).

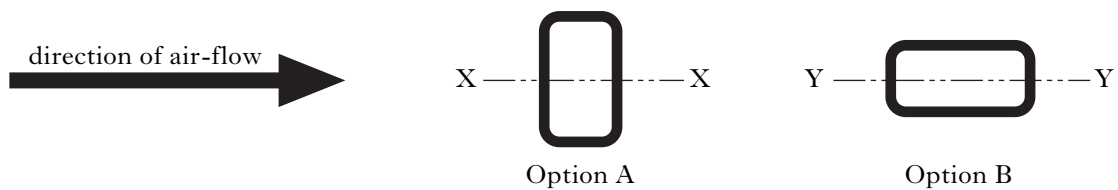

Figure Q7(b)

- (a) (i) State **one** advantage and **one** disadvantage of Option A compared with Option B, from structural and aerodynamic viewpoints. 1
- (ii) State the main advantage of using hollow sections for beams, compared with solid sections. 1

The roofbar shown in Option B is a **standard** mild-steel rectangular hollow section of dimensions $50 \times 30 \times 2.6$ mm. It can be considered as a simply-supported beam of length 1.5 m with a central point-load. The maximum allowable stress due to bending is 100 N/mm^2 .

- (b) Calculate, for Option B:
- (i) the maximum central point load; 3
- (ii) the maximum deflection due to bending. 2

7. (continued)

The manufacturer has decided to investigate the new profile shown in Figure Q7(c).

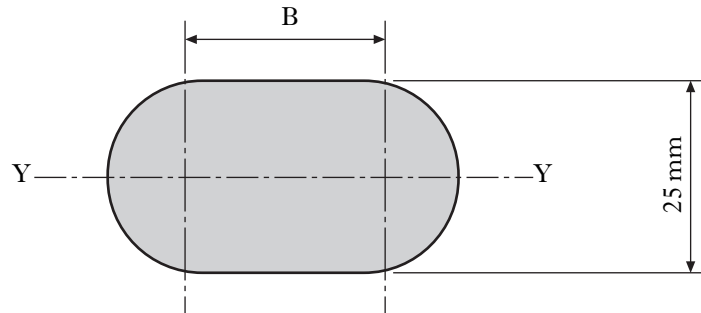

Figure Q7(c)

This option is a simply-supported beam of 1.5 m length with a central point-load of 1 kN. The **solid section** of the roofbar is aluminium alloy, which has a maximum bending stress of 90 N/mm^2 .

- (c) Calculate the unknown dimension B shown in Figure Q7(c). 5
- (d) Calculate the radius of curvature of the loaded roof bar. 2

Further wind-tunnel testing is used to determine the aerodynamic force acting on various roofbar profiles. A simplified diagram of the test rig is shown in Figure Q7(d).

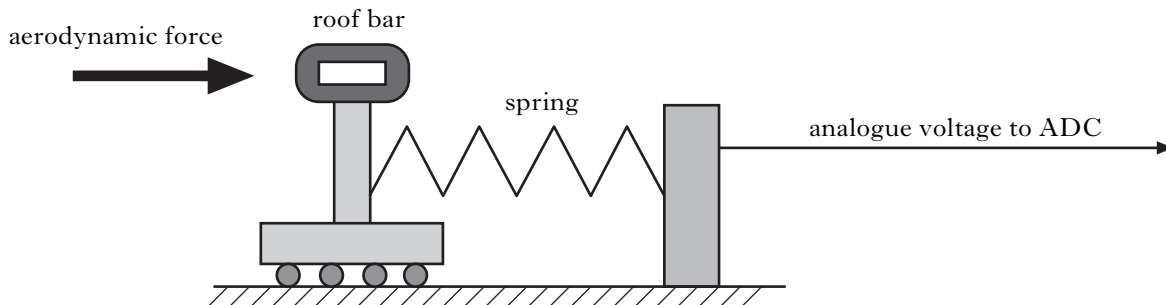

Figure Q7(d)

The compression of the spring is proportional to the applied aerodynamic force. The test rig outputs an analogue voltage to an analogue-to-digital converter (ADC) which is proportional to spring compression. The ADC has a 6-bit resolution and a reference voltage of +6 V. The ADC uses an op-amp with a feedback resistor of $20 \text{ k}\Omega$, and digital logic voltages of 0 V and 5 V.

Worksheet Q7 shows an incomplete diagram of the ADC.

- (e) On **Worksheet Q7**, complete the circuit for the ADC, showing all component values. 5
 - (f) Calculate the analogue voltage input required to produce a binary output of 101111. 1
- (20)**

[Turn over

8. The water intake to a hydro-electric power station has a grille placed across it to prevent floating debris such as leaves and tree branches from entering the system and damaging the turbine. However, the grille must be cleared frequently in order to maintain the flow of water. An automatic debris-clearing machine is used for this purpose.

When a start switch is pressed, each of the four sections is cleared in turn by a mechanism. After each section has been cleared, the debris is dumped onto a chute adjacent to the intake. A microcontroller-based system controls the mechanism.

The mechanism consists of three parts: a carriage, an arm, and a debris grab, as shown in Figure Q8(a).

The carriage is **driven** horizontally along the gantry by a d.c. motor, and its position is **monitored** by a linear potentiometer via an ADC. The carriage stops in five distinct horizontal positions within the range 0 – 255 from left to right.

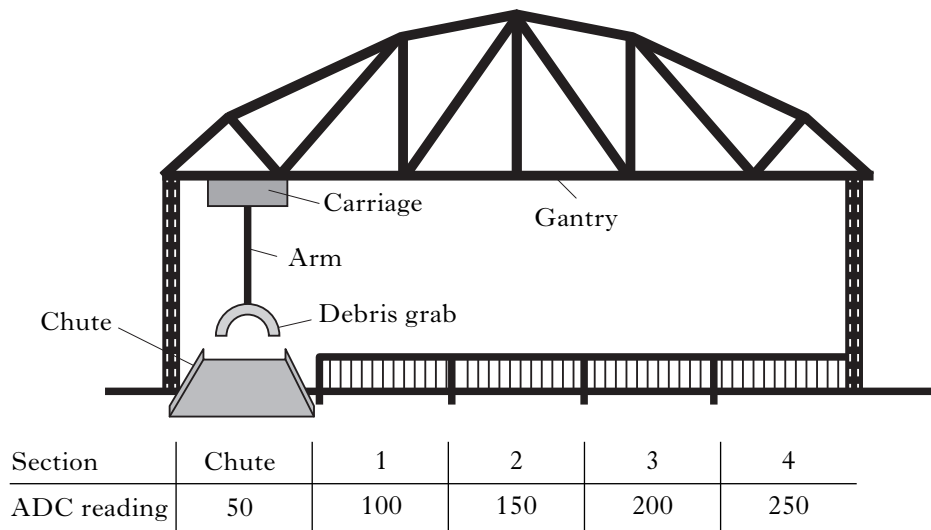

Figure Q8(a)

The relevant Port B microcontroller connections are shown in Figure Q8(b).

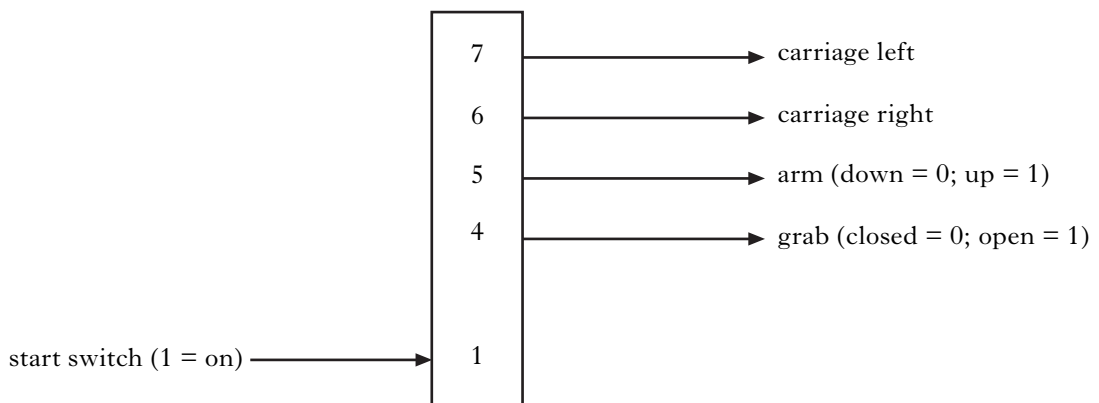

Figure Q8(b)

8. (continued)

Marks

A sub-procedure *grab* works in the following sequence.

The debris grab opens and the arm is instructed to move down. Five seconds later, the debris grab is actuated to close.

After 2 seconds the arm is actuated to move up. A five second delay follows to allow the arm to move up fully.

(a) Write, in assembler code, the sub-procedure *grab*.

2

Note: The sub-procedure *wait* creates a delay of 0.1 seconds multiplied by the value held in the Working Register W.

A sub-procedure *dump* works in the following sequence.

The carriage travels left and halts at the chute then waits for 1 second. The debris grab opens for 2 seconds then closes.

(b) Write, in assembler code, the sub-procedure *dump*.

3

Note: The sub-procedure *adcread* is prewritten and stores the actual position of the debris grab in the register file ACTUALPOS, which has been set up.

The main program monitors the start switch. When the switch goes high, the carriage travels to each of the four sections in the order 1, 2, 3 and 4, using the values specified in Figure Q8(a). After the debris has been lifted from a section, using the sub-procedure *grab*, the carriage travels **left** to return to the chute to drop the collected debris, using the sub-procedure *dump*. The sequence repeats continuously until the start switch goes low.

(c) Write, in assembler code, the main program for the sequence described above.

4

Note: The prewritten sub-procedure *adcread* stores the actual position of the carriage in the register file ACTUALPOS. The register file DESIREDPOS stores the desired position of the carriage. ACTUALPOS, DESIREDPOS and COUNTER have been set up. Assume that TRISB has been initialised.

A simplified diagram of the symmetrical gantry is shown in Figure Q8(c), for a particular loading.

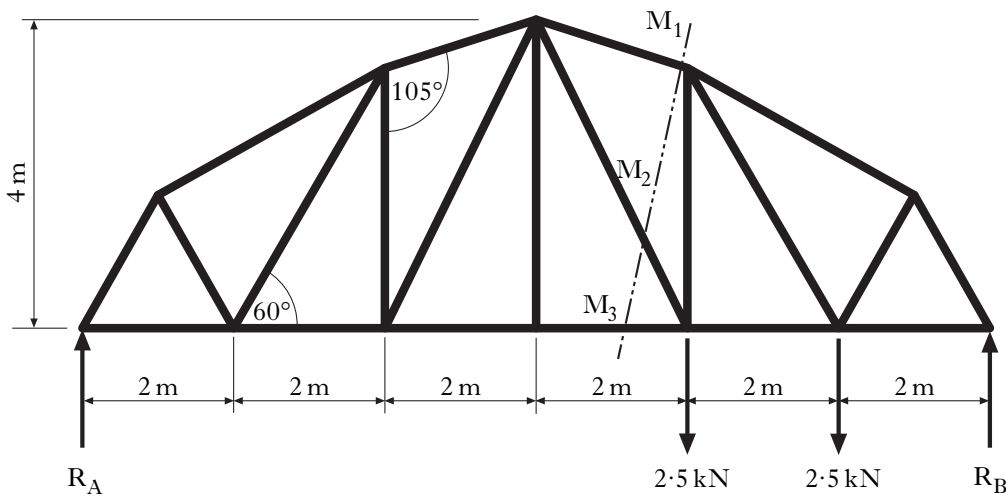

Figure Q8(c)

(d) Calculate the unknown reaction forces R_A and R_B .

2

(e) Using the *method of sections*, calculate the **magnitude** and **nature** of the forces acting in M_1 , M_2 and M_3 , by analysing the section of frame to the left of the cut shown in Figure Q8(c).

9

9. A water-fountain display consists of three fountains, each of which is controlled by a solenoid-operated valve via an electronic sequential-control system.

(a) State the difference between a time-based and an event-based sequential-control system. 1

The table below shows the sequence of valve operation.

Clock Count	Valve A	Valve B	Valve C
0	0	0	1
1	0	0	1
2	0	1	1
3	0	1	1
4	0	1	1
5	0	1	1
6	1	1	1
7	1	1	1
8	1	1	1
9	1	1	0
reset			

Worksheet Q9(a) shows an incomplete diagram of the sequential-control system.

(b) On Worksheet Q9(a), complete the diagram for the sequential-control system. 3

Information Sheet Q9 shows an electronic circuit comprising an integrator and a voltage-controlled oscillator, (VCO).

(c) Derive the equation of V_{out} in its simplest form, in terms of t . 3

(d) Explain the operation of the VCO. 3

The frequency-divider circuit shown in Figure Q9(a) is used to increase the duration of the clock pulses.

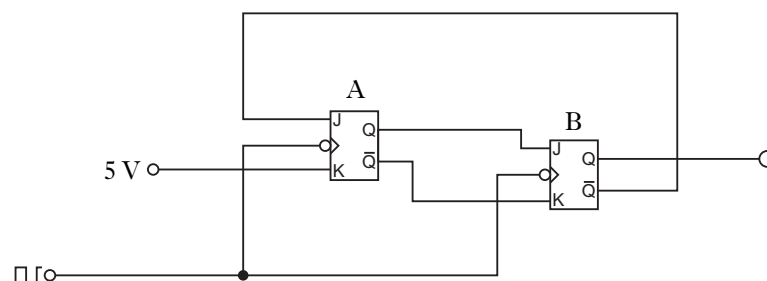

Figure Q9(a)

9. (continued)

Marks

The circuit uses negative-edge-triggered J-K bistables. The truth table for a J-K bistable is shown in the table below.

J	K	Q
0	0	stays the same on clocking
1	0	Q = 1 (set) on clocking
0	1	Q = 0 (reset) on clocking
1	1	Q toggles to its opposite state on clocking

Worksheet Q9(b) shows an incomplete timing diagram.

- (e) On **Worksheet Q9(b)** complete the timing diagram for the Q and \bar{Q} outputs of bistable A and bistable B.

4

The sequence of valve operation is being revised, and is now to be controlled by a microcontroller. The relevant PORTB connections for valve A are shown in Figure Q9(b).

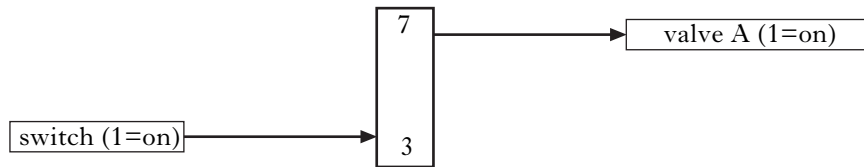

Figure Q9(b)

The control sequence, consisting of a main program and a sub-procedure *delay*, sets the time period for which valve A is opened or closed. The time period is variable, and is based on the value held in the register file TIMEVAL, which can be changed in the main program.

Sub-procedure *delay* consists of a three-times repeat loop, which has the effect of multiplying by three the value held in TIMEVAL. During each loop a time delay is created by transferring the value in TIMEVAL into the Working Register and then calling the sub-procedure *wait*.

- (f) Write, in assembler code, the sub-procedure *delay*.

2

Note: The sub-procedure *wait* creates a delay of 100ms multiplied by the value held in the Working Register W when the procedure is called. When transferred to W the value in TIMEVAL is copied and is still retained in the file for further use. Register files TIMEVAL and COUNT have been set up.

The main program tests the switch in a loop. When the switch goes high, valve A opens for a specified time, and then closes for the same time in a five-times repeat loop, using sub-procedure *delay*. Before *delay* is called, the delay time is set up by copying the value held in TIMEVAL into the Working Register. Initially the value in TIMEVAL is set to 60 to produce a delay of 18 seconds and is then decreased to reduce the delay by 3 seconds on each subsequent repeat. If the switch is still high at the end of the five-times repeat loop, the whole sequence repeats.

- (g) Write, in assembler code, the main program for the control of valve A.

4

Note: The register file COUNTER has been set up. TRISB has been initialised.

(20)

[END OF QUESTION PAPER]

[BLANK PAGE]

[BLANK PAGE]

[BLANK PAGE]

FOR OFFICIAL USE

--	--	--	--	--	--

X036/702

NATIONAL
QUALIFICATIONS
2011

FRIDAY, 27 MAY
9.00 AM – 12.00 NOON

**TECHNOLOGICAL
STUDIES**
ADVANCED HIGHER
Worksheets for Questions 1,
4, 5, 7, 9(a) and 9(b)
Information Sheet for Q9

Fill in these boxes and read what is printed below.

Full name of centre

Town

Forename(s)

Surname

Date of birth

Day Month Year

--	--	--	--	--	--

Scottish candidate number

--	--	--	--	--	--	--	--	--	--

Number of seat

To be inserted inside the front cover of the candidate's answer booklet and returned with it.



WORKSHEET Q1

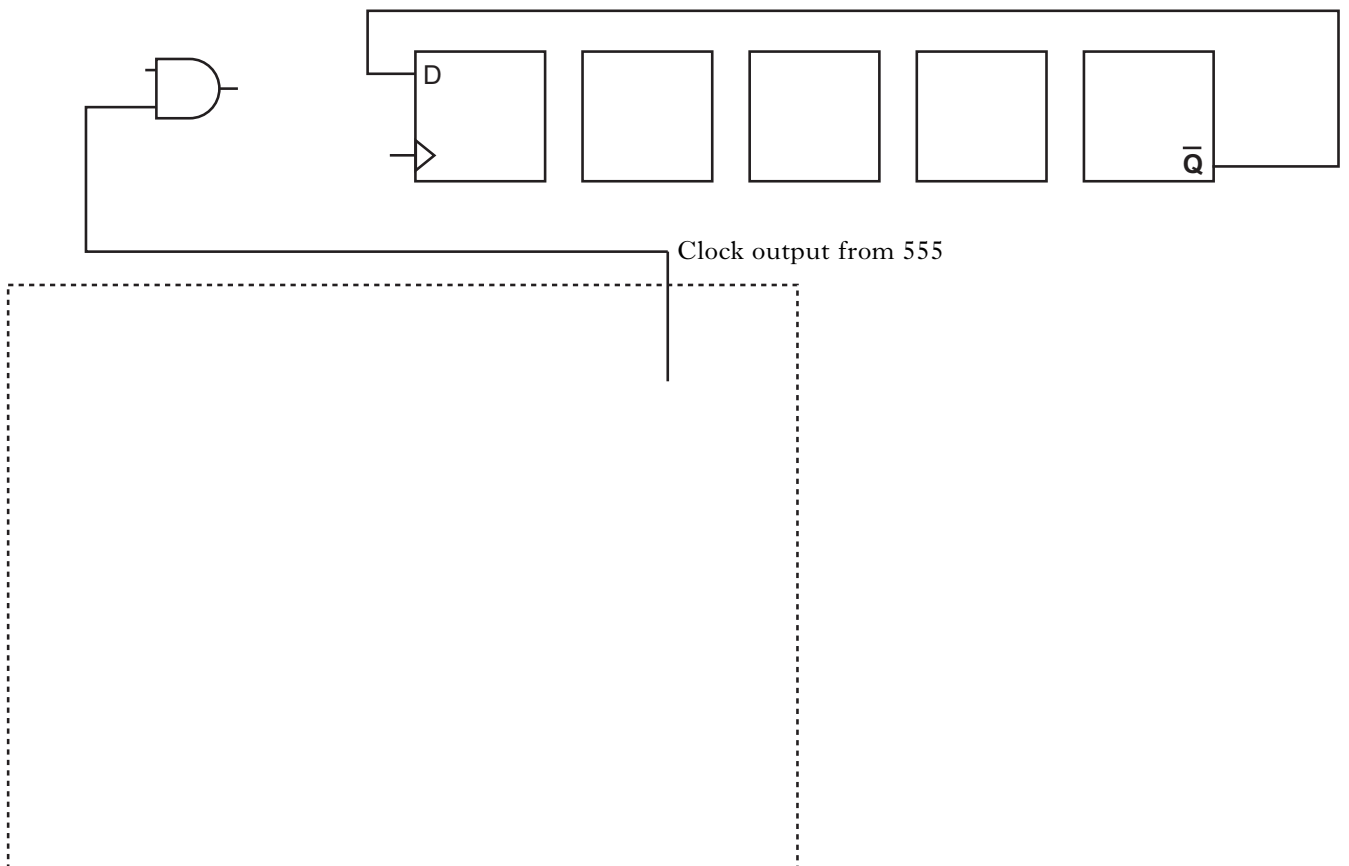
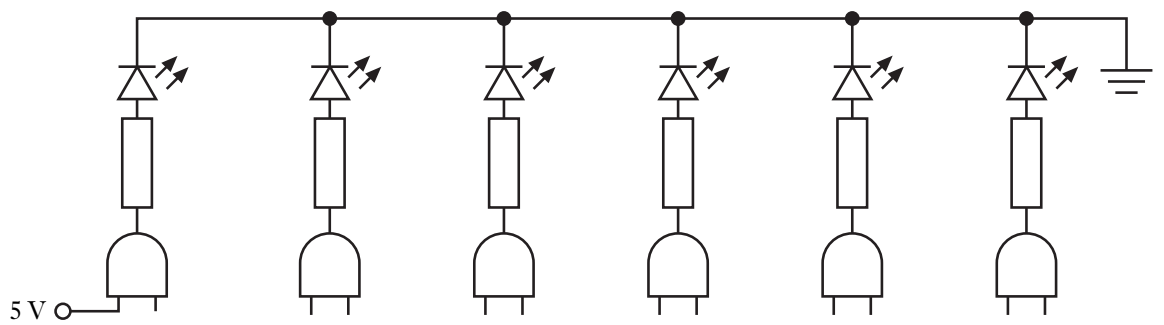
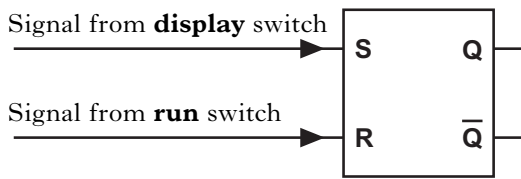

WORKSHEET Q4

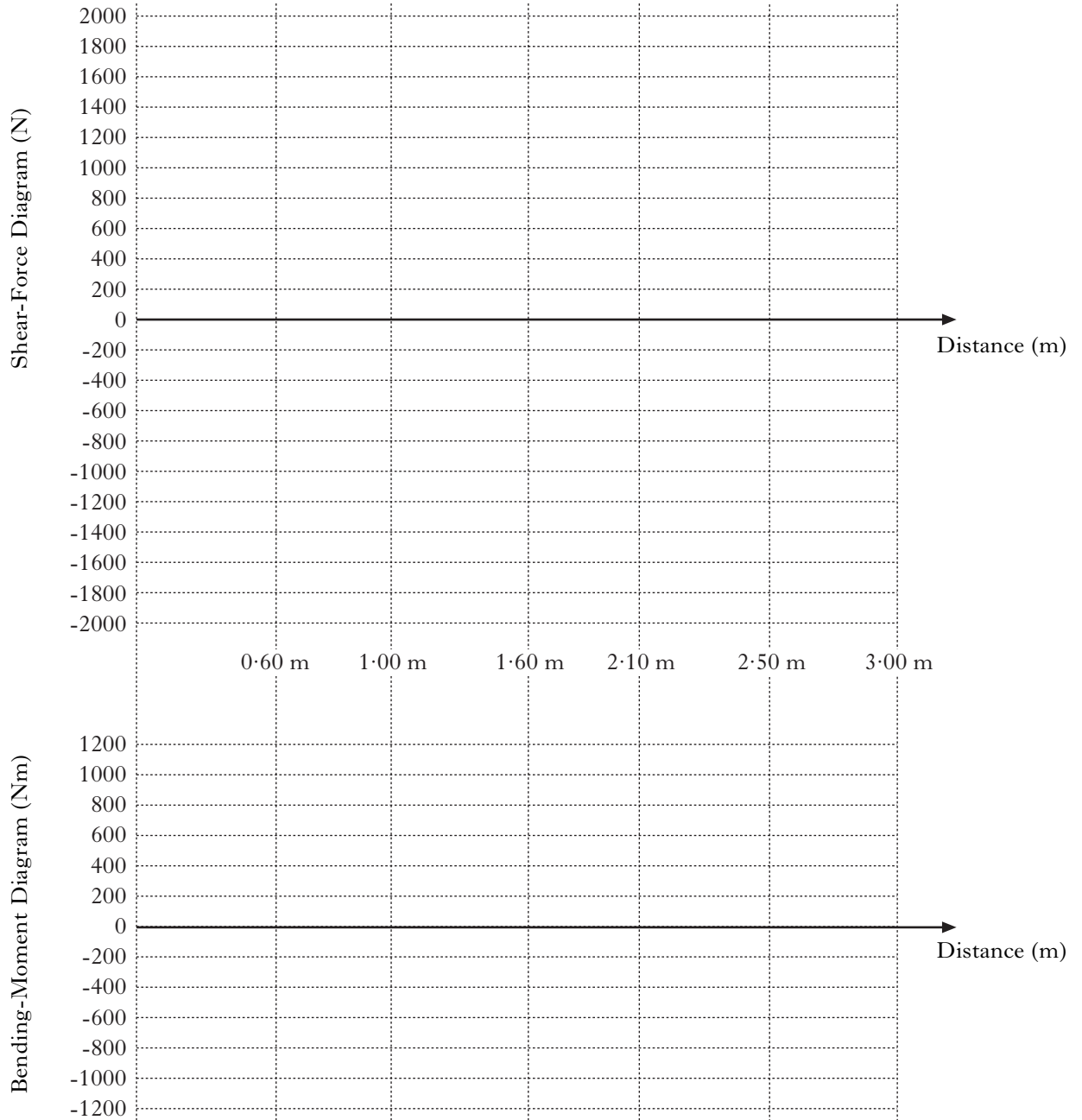
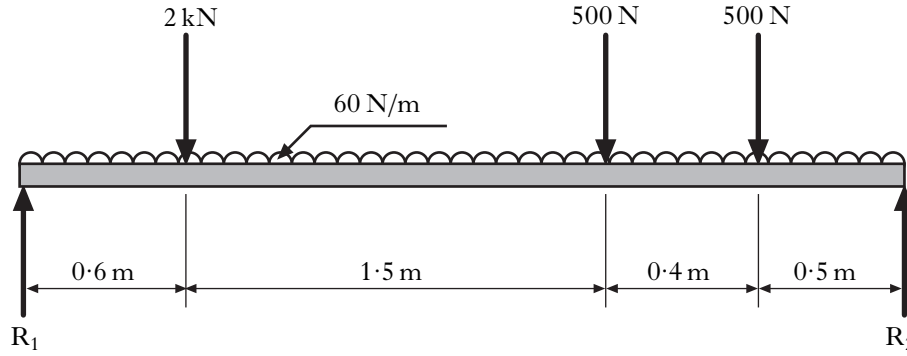

DISTANCE FROM LEFT END (m)	0.00	0.60	1.00	1.60	2.10	2.50	3.00
BENDING MOMENT (Nm)							

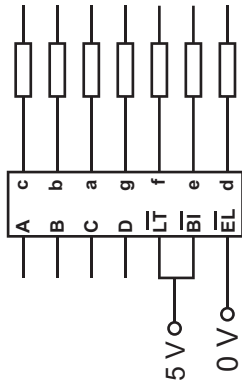

7- Segment Display

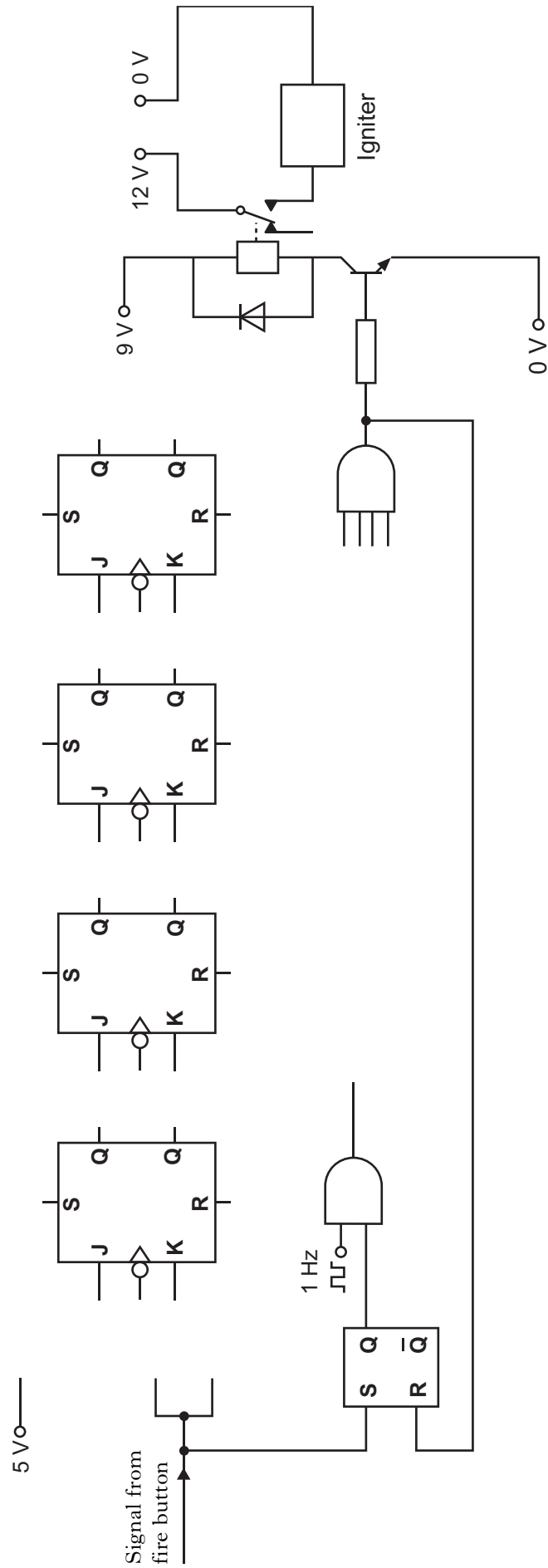

WORKSHEET Q7

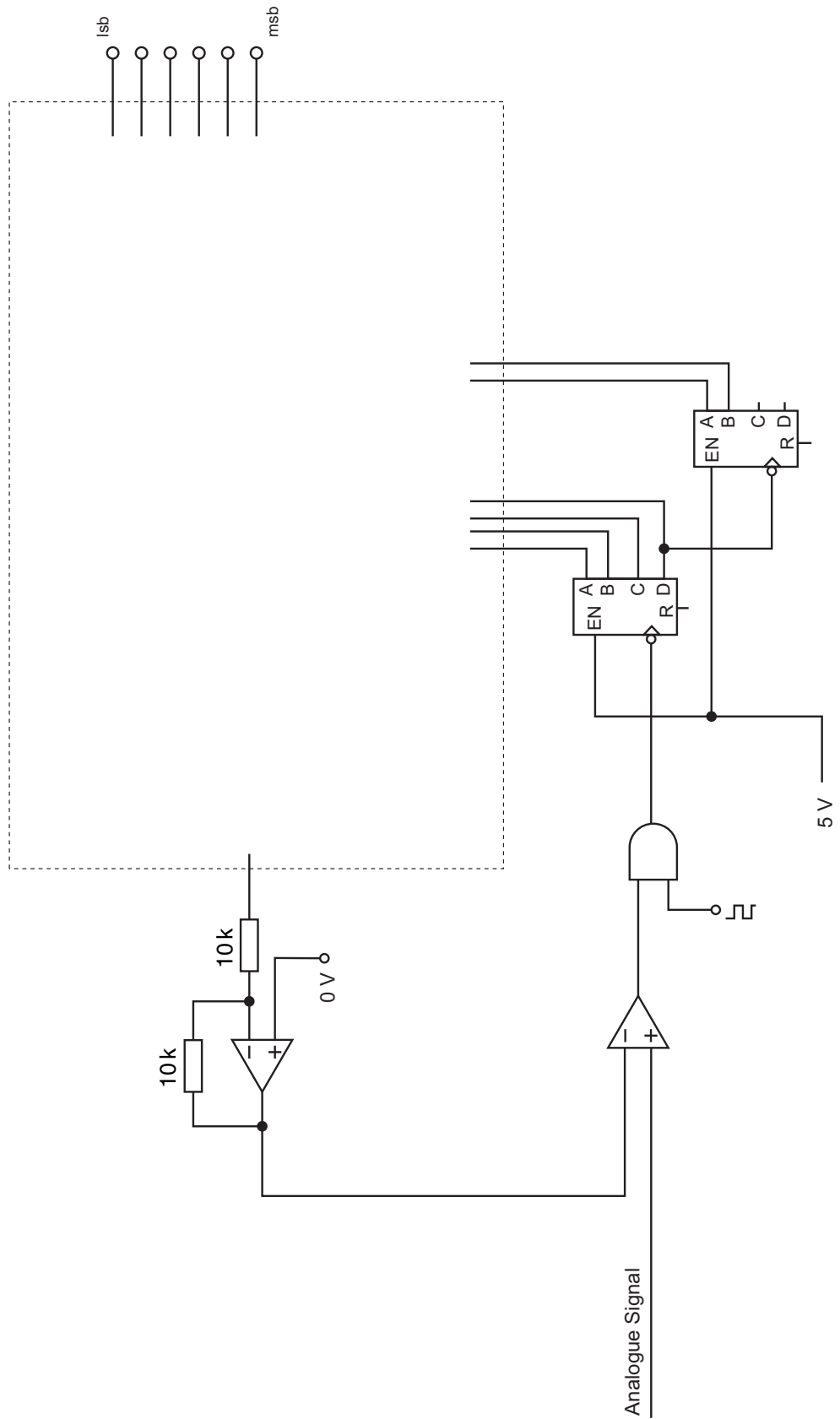

WORKSHEET Q9(a)

V_{cc} _____ V_{cc}

○ — to valve A

○ — to valve B

○ — to valve C

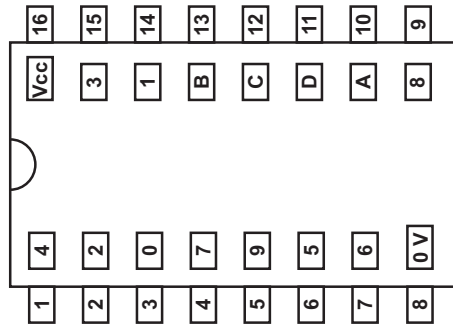

DECODER

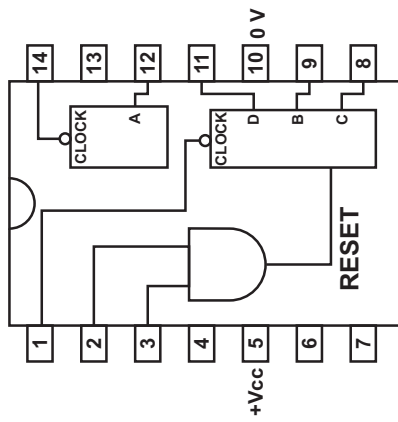

BINARY COUNTER

0 V _____ 0 V

WORKSHEET Q9(b)

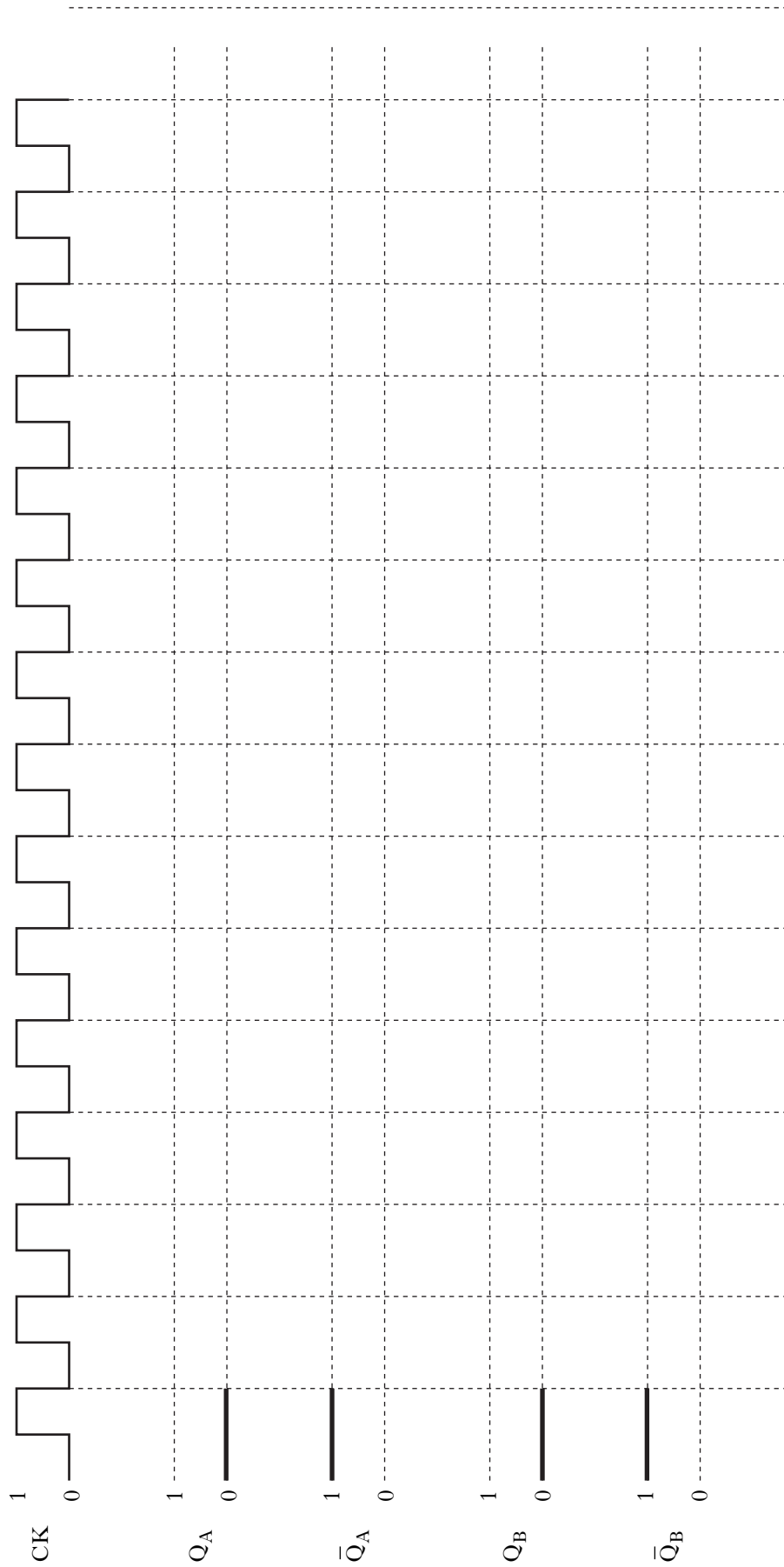

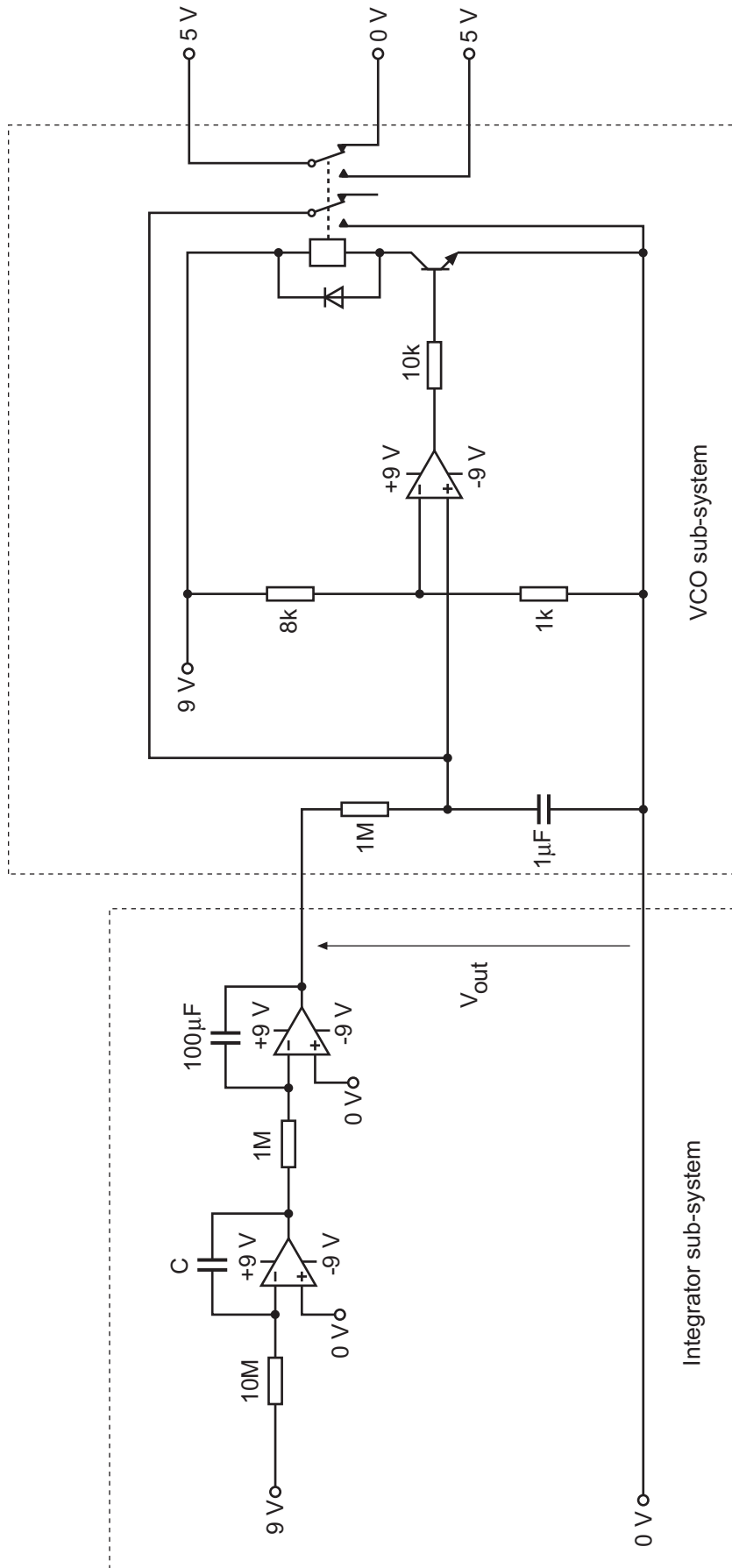

[END OF WORKSHEETS]