

STAPLE HERE

FOR OFFICIAL USE

--	--	--	--	--

X033/13/01

NATIONAL
QUALIFICATIONS 2014

THURSDAY, 8 MAY
1.00 PM – 4.00 PM

**GRAPHIC
COMMUNICATION
ADVANCED HIGHER**

Fill in these boxes and read what is printed below.

Full name of centre Town

Forename(s) Surname

Date of birth

Day	Month	Year	Scottish candidate number	Number of seat
<input type="text"/>	<input type="text"/>	<input type="text"/>	<input type="text"/>	<input type="text"/>

80 marks are allocated to this paper.

- 1 Answer all questions.
- 2 Read each question carefully before you answer.
- 3 Written answers may be in **ink** or **pencil**.
- 4 Drawings and sketches **must be in pencil**.
- 5 Coloured pencils may be used when sketching.
- 6 Dimensions are given in millimetres or as stated.
- 7 Orthographic drawings are in third angle projection.
- 8 The leaflet for Question 1 has been supplied separately. Please ensure that you have this leaflet.
- 9 **At the end of the examination**
 - check that your name is on every sheet;
 - put the sheets in correct numerical order;
 - place this sheet on top of the others;
 - join all sheets together by **stapling** at the top left-hand corner;
 - before leaving the examination room, you must give these sheets to the invigilator (if you do not you may lose all the marks for this paper).

Marks Grid

Question	Marks
1	
2	
3	
4	
5	
6	
7	
8	
9	
10	
Total Marks	



[BLANK PAGE]

Design Elements/Principles have been given below.

Please refer to “**Moray Monster Trails**” leaflet.

For the terms below:

- circle to show whether a Design Element or Design Principle;
- describe with direct reference to the leaflet, how the design element or design principle has been used in the leaflet.

(i) **White space:** Design Element/Design Principle

Description:

2

(ii) **Balance:** Design Element/Design Principle

Description:

2

2

(vi) **Value:** Design Element/Design Principle

Description:

2

(iii) **Shape:** Design Element/Design Principle

Description:

2

Total (12)

Candidate's Name _____

The graphic shown below is a page out of a magazine.

Rule off and annotate the given page to show the Desktop Publishing terms listed below.

- Column structure
- Gutters
- Body text
- Text run-around
- Reverse text
- Sub Headline

(6)

A little place we know

CASA ALLA SCALA,
Sicily

On a rocky little outcrop above a harbour and the deep blue sea, Casa alla Scala is a chic, three-bedroomed apartment in the charming fishing village of Santa Maria La Scala in eastern Sicily.

WHAT'S IT LIKE?
The apartment inhabits the whole first floor of a grand villa and is beautifully furnished in a classic-contemporary Italian style. If you want to switch off but, like me, get twitchy by a pool, Casa alla Scala offers the perfect mix of relaxation with a window on to Sicilian life – breakfast on the terrace and watch the busy fishermen below.

WHAT'S FOR SUPPER?
Locally caught seafood – I've never eaten fresher fish. There are two simple, sensibly priced restaurants overlooking the bay, both a five-minute stroll away. At La Grotta you choose your fish from the counter before it's grilled and dressed with olive oil and lemon juice. A classic lemon granita was the perfect finish. Next door, the owner of Trattoria Scalo Grande recommended linguine with gamberini (red prawns), parsley and olive oil – delicious. Our €38 bill for two included half a litre of good house wine and a tomato salad.

BEDTIME
There are two doubles and one twin room, all spacious, filled with elegant antiques and each with its own shower room or bathroom (think rainfall showers, Jacuzzi tubs and fluffy Armani towels). Wake up to uninterrupted sea

views through the terrace doors, or a harbour view from the second double.

HANGING OUT
Relax on the terrace or stroll over to a swimming platform on the harbourside for a dip in the sea. A village shop sells bread, milk and other basics; walk a little further and poke your head into the pretty 17th-century church. Lunch at home before retiring for a siesta, but don't miss the shrill whistle of the gelateria van come late afternoon. Treat yourself to brioche con gelato, the typical Sicilian snack – ice cream in a brioche bun that's eaten like a sandwich.

THINGS TO DO NEARBY
The coastal city of Acireale is a 10-minute drive away. Visit the tiny bakery at 51 Corso Umberto, with a fired oven, or have an espresso at Barocco at number 34. Try Pasticceria Castorina (109 Corso Savoia) for a cooling almond granita. Local almonds, pistachios, aubergines, tomatoes and lemons reign supreme. It's worth driving 40 minutes south to Catania's sprawling market; the huge range of fish will excite any cook (you can cook supper on the outside kitchen's barbecue). More sophisticated but touristy Taormina is 40 minutes north – explore the shops then take the cable car down to the pretty beach. A trip to Etna is a must. On the way, pick up lunch at Viagrande's traditional Gran Caffè Urna (36 Piazza Urna); try its pizza Siciliana – fried and stuffed with local Tuma cheese and anchovies. Drive on to Zafferana Etnea (famous

Sea dream, from top: the villa's terrace overlooks the sea; from the outside; the master bedroom; courgettes at Catania's large market; friendly service at family-run La Grotta; brioche con gelato

for honey), then take the winding Etna road through the olive and citrus groves and vineyards that thrive in the fertile soil to the base of the volcano (eerily cool and black) at Rifugio Sapienza.

WHO'D LOVE IT?
Couples who want a stylish base from which to explore Sicily (you definitely need to hire a car). The second double room is at the far end of the apartment, so it's ideal for a family holidaying with another couple or grandparents.

How to book A week at Casa alla Scala costs from £2,730 (sleeps six), including linen, towels and Wi-Fi (think sicily.com). The Think Sicily team can arrange provisions on arrival, day trips, cookery classes, an in-house cook and more. It's a 30-minute drive from Catania airport.

sainsburismagazine.co.uk 135

3

Typefaces generally fall into one of three categories or groups. Explain, with the aid of sketches, each of these three groups.

(i)

1

(ii)

1

(iii)

1

Total (3)

4

Explain the following printing terms.

(i) Camera-ready copy

(ii) Calendaring

(iii) Paper opacity

1

1

Total (3)

Section A

Candidate's Name _____

5

The following commands are associated with Computer Aided 3D Modelling.

- (i) Boolean Intersection
- (ii) Surface of Revolution
- (iii) Solid Primitive

Describe, **with the aid of sketches**, these 3D modelling commands.

(i)

2

(ii)

2

(iii)

2

Total (6)

6

Lighting in 3D modelling techniques is important to add realism to your models.

Explain, **with sketches**, the following CAD lighting terms.

- (i) Distant light:

1

- (ii) Spotlight:

1

- (iii) Ambient light:

1

Total (3)

Candidate's Name _____

The complete elevation and incomplete plan of a solid right cone are given below.

Draw, the complete:

- (a) plan;
- (b) end elevation.

Show all hidden detail. (12 marks)

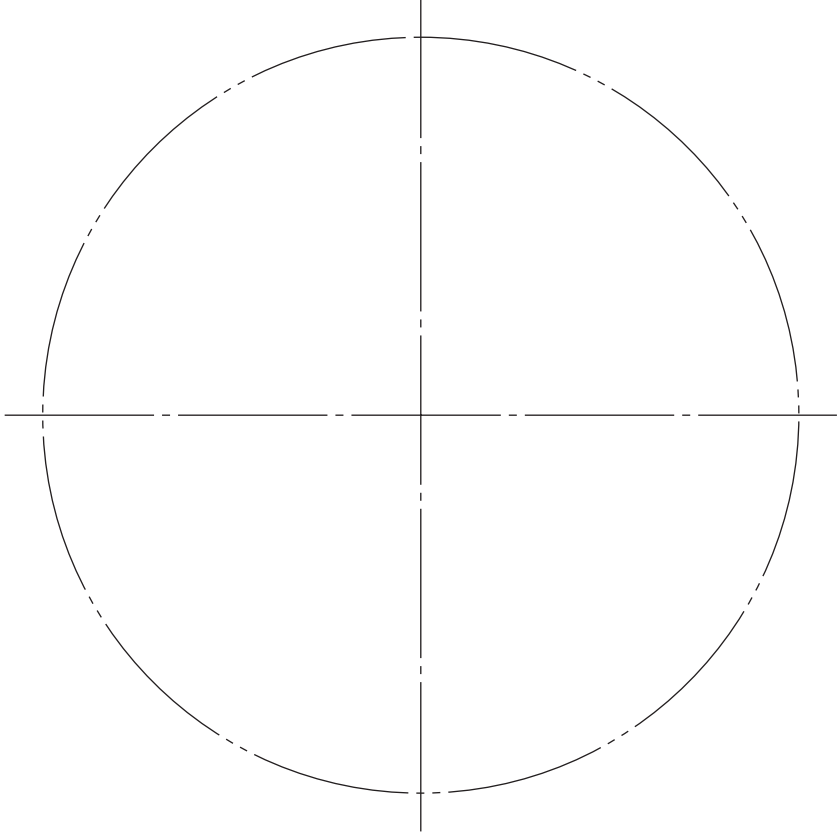

PLAN

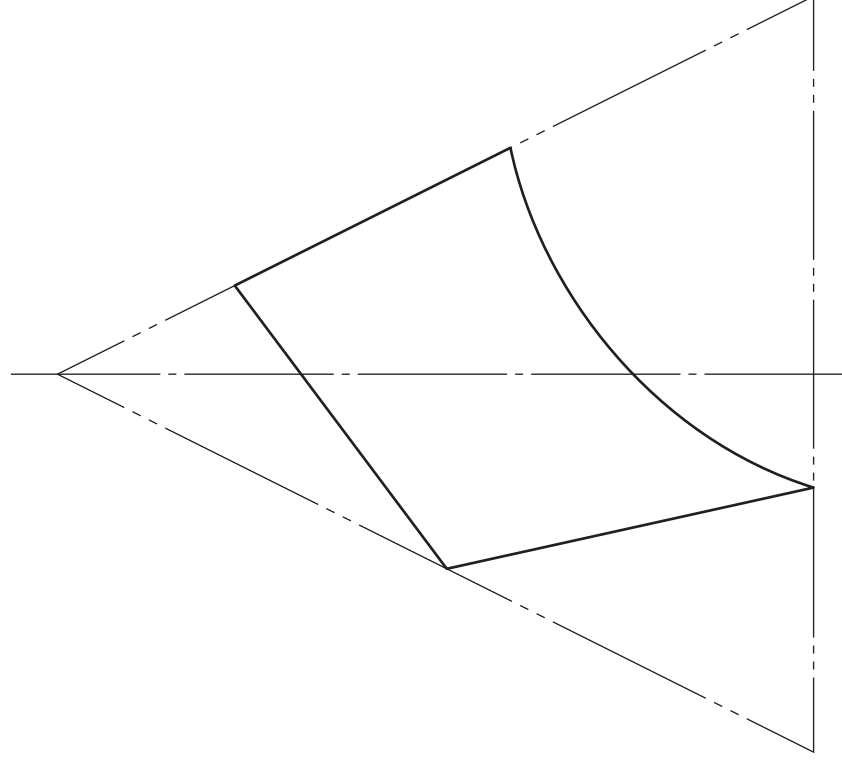

ELEVATION

END ELEVATION

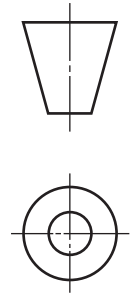

a	
b	
c	
d	
e	
f	
g	
h	
i	
j	
k	
l	
m	
n	

Candidate's Name _____

The plan and incomplete elevation of an intersecting triangular and cylindrical pipe are given below.

Draw, in the positions shown:

- (a) the complete elevation;
- (b) the end elevation to the right of the elevation.

Show all hidden detail.

(14 marks)

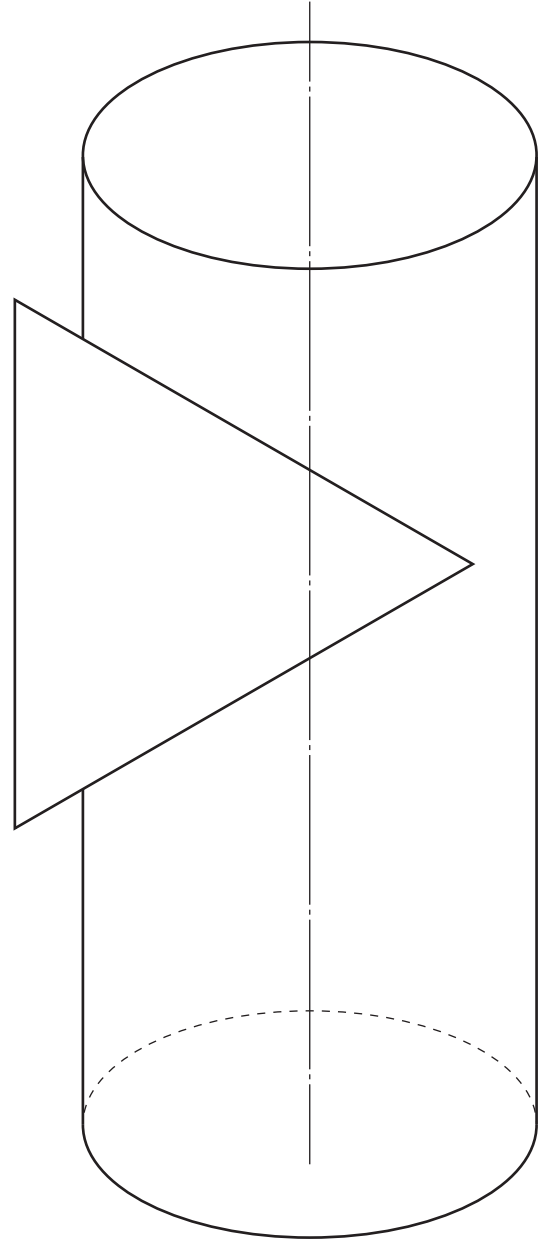

PLAN

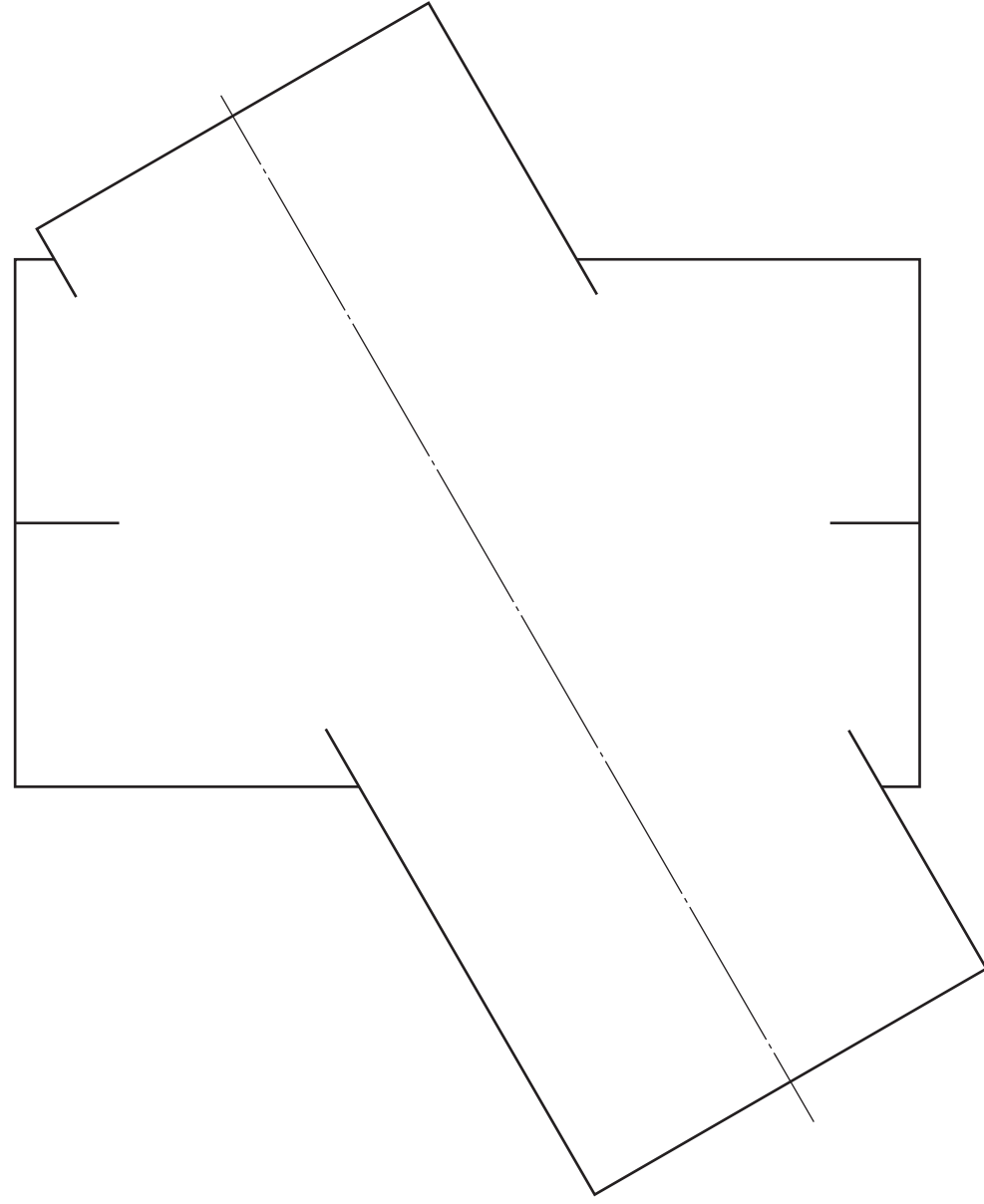

ELEVATION

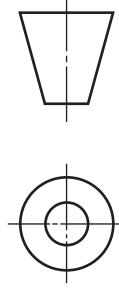

END ELEVATION

Candidate's Name _____

a	
b	
c	
d	
e	
f	
g	
h	
i	
j	
k	
l	
m	
n	

9

Section B 9

The complete elevation and incomplete plan of a solid oblique cone are given.

Draw:

- (a) the complete plan;
- (b) the surface development along seam **AB**.

Show all hidden detail. (11 marks)

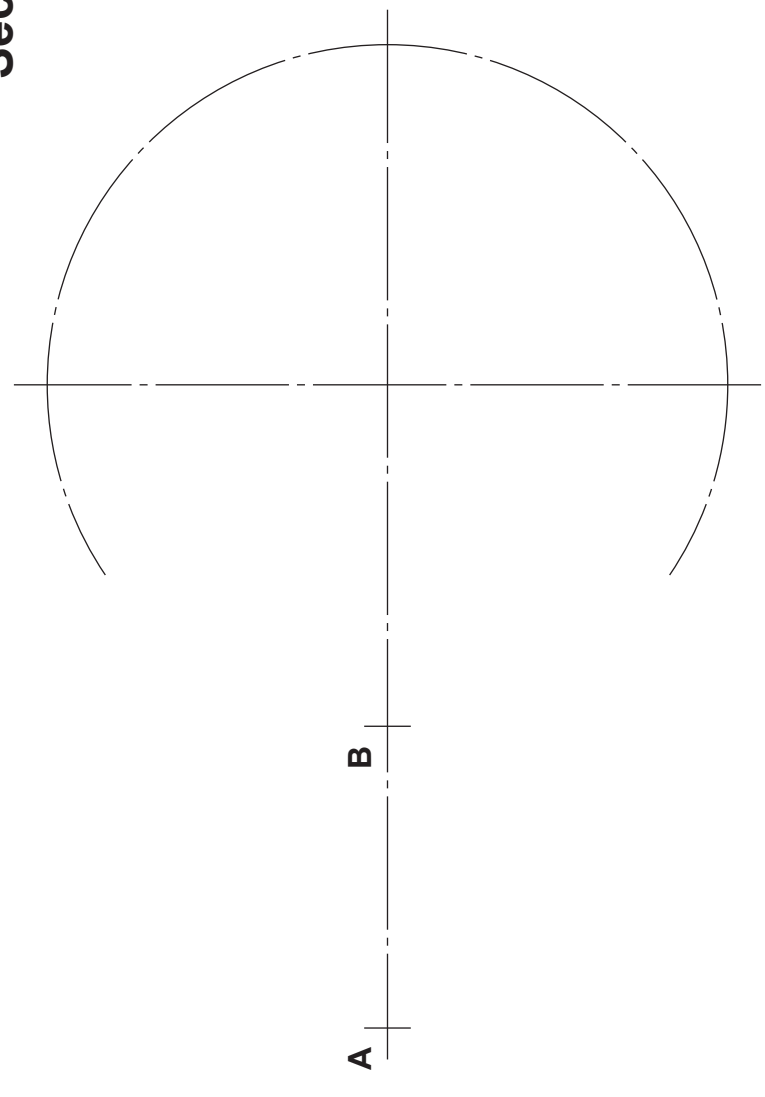

PLAN

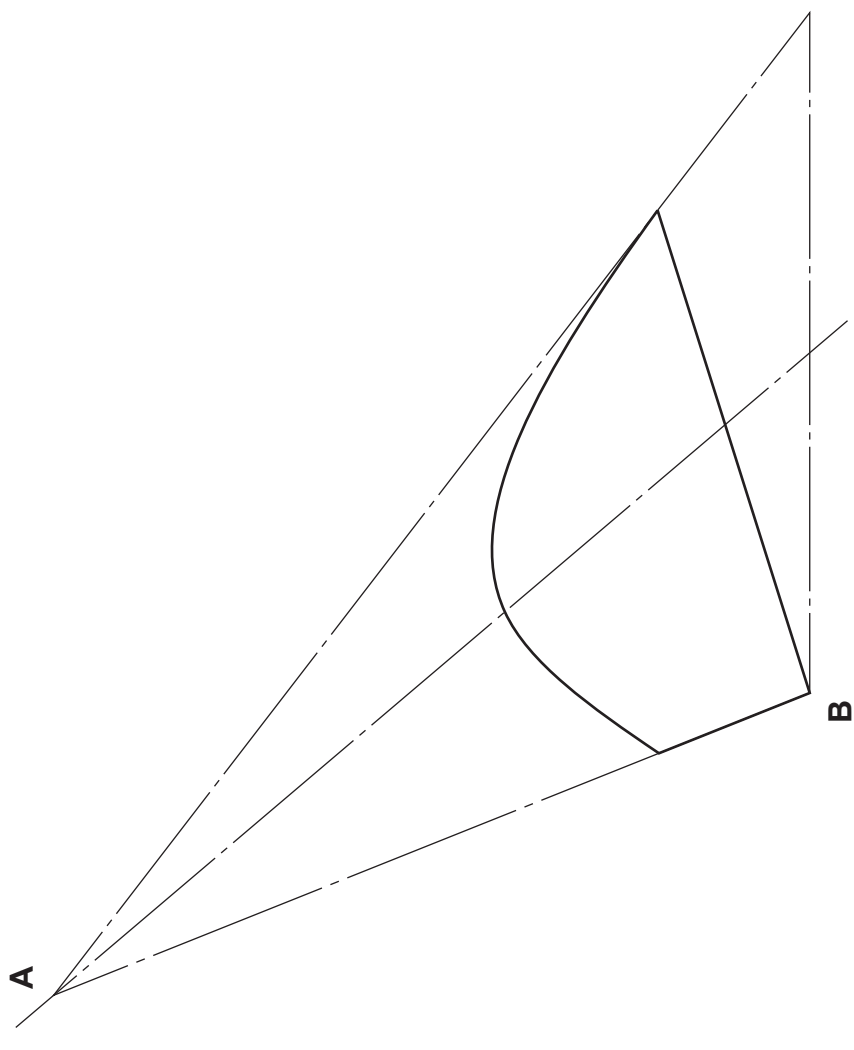

ELEVATION

B SURFACE DEVELOPMENT

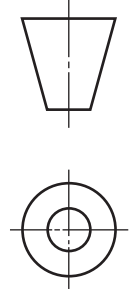

a	
b	
c	
d	
e	
f	
g	
h	
i	
j	
k	
l	
m	
n	

Candidate's Name _____

The elevation and plan of a transition piece attached to a cylinder are shown.

Draw, starting at AB, the surface development of the transition piece only, with the seam in the position given.

(10 marks)

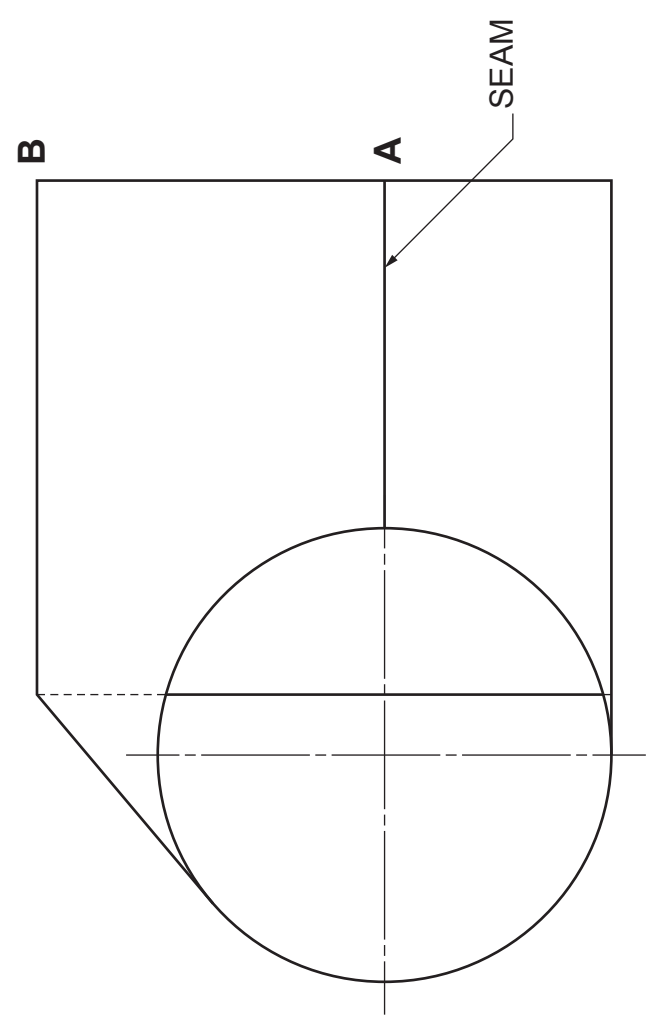

PLAN

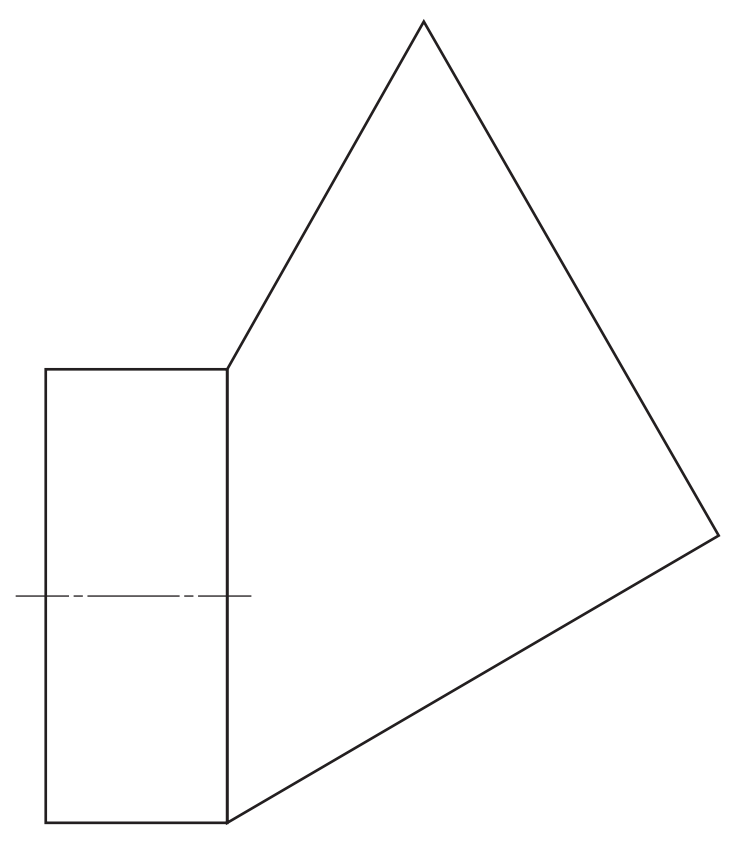

ELEVATION

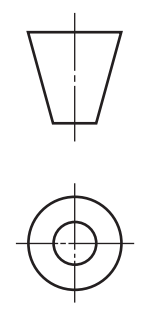

A _____ B

SURFACE DEVELOPMENT

a	
b	
c	
d	
e	
f	
g	
h	
i	
j	
k	
l	
m	
n	

X033/13/11

NATIONAL THURSDAY, 8 MAY
QUALIFICATIONS 1.00 PM – 4.00 PM
2014

GRAPHIC
COMMUNICATION
ADVANCED HIGHER
Leaflet for use with
Question 1





MONSTER TRAILS
MORAY

WHITEASH
- Winding walks Car Park

The Fochabers Ring
Grade - **▲ DIFFICULT**
A varied and full-on cross country trail you'll want to ride again and again! A 'no pain, no gain' climb up to the monument and then the fun starts. A sense of adventure - essential! Hobbit's hairy feet - optional! To complete the ring is a fair outing of around 8 Km.

Fochabers Freeride
Grade - **● EXTREME**
This trail is for **advanced riders only**. No matter how good you are - **WALK IT BEFORE YOU RIDE IT!** Initially built almost entirely by volunteers, this is where the whole Monster Trails project started. Follow 'The Ring' to the monument and then prepare for some very wild and scary riding! The top section of the Freeride trail includes big technical 'northshore' wooden structures. Please make sure you're capable of this style of riding - most of us aren't. The second section is big earth features, drops and jumps. After section 2, join 'The Ring' back to the car park.

ORDIEQUISH
Start here if you're looking for easier routes, but also the Gully Monster and some longer routes - something for everyone!

The Soup Dragon
Grade - **■ MODERATE**
This is just pure fun - a fun packed friendly route that can be enjoyed at any level. You're in control! Just one catch - you first got to go up! Don't worry, your climb up will be well rewarded. (It's soup time!) Want just a bit more? Keep climbing for an add on - 'The Dragon's Tail'. Allow 45 mins - 5 km (3 miles) round trip from the car park. Then do it again!

The Haggis
Grade - **■ MODERATE**
You just want more don't you? You want to meet The Haggis. This beastie, well known for running around mountains has lately taken up mountain biking. He calls it progress. A great trip - full of interest - loads of fun, a fair distance but not too technical. The Haggis Connection is your gateway to Ben Aigan if you really fancy a long day.

Gorzilla
Grade - **■ MODERATE**
A strange beast, twice the size of any man, who builds trails through the wood when you're sleeping. Gorzilla gave up eating mountain bikers and now survives on porridge. A great flowing route - cruise it or ramp it but you'll certainly enjoy it. As with others here, can be linked to others like The Haggis. Allow 1 hr.

The Gully Monster
Grade - **◆ SEVERE**
An awesome trail of monster proportions! You won't have ridden anything quite like this before. Full of technical interest. This isn't your domain - this is the home of the Gully Monster.

WHITEASH
- Winding walks Car Park

The Fochabers Ring
Grade - **▲ DIFFICULT**
A varied and full-on cross country trail you'll want to ride again and again! A 'no pain, no gain' climb up to the monument and then the fun starts. A sense of adventure - essential! Hobbit's hairy feet - optional! To complete the ring is a fair outing of around 8 Km.

Fochabers Freeride
Grade - **● EXTREME**
This trail is for **advanced riders only**. No matter how good you are - **WALK IT BEFORE YOU RIDE IT!** Initially built almost entirely by volunteers, this is where the whole Monster Trails project started. Follow 'The Ring' to the monument and then prepare for some very wild and scary riding! The top section of the Freeride trail includes big technical 'northshore' wooden structures. Please make sure you're capable of this style of riding - most of us aren't. The second section is big earth features, drops and jumps. After section 2, join 'The Ring' back to the car park.



KEY TO MAP

- Trail Start
- Cycle Trail
- Riding direction
- Car Park (Charge)
- Non-FC Woodland
- Main Road
- Secondary Road
- Other Road
- Tablets
- Refreshments
- Road / Track
- Railway

Enjoy Scotland's outdoors responsibly

- Take responsibility for your own actions
- Leave no trace
- Comply with the wishes of other people

KNOW THE CODE OF THE CODE

Know the Code of the Code

NOTE FOR SAFETY: ALL waymarked cycle trails MUST BE RIDDEN ONLY IN THE DIRECTION SHOWN.

Trail problems? You're out there, so if you see any problems that need fixing - let us know (see Moray and Aberdeenshire FD contact details).

BEN AIGAN

The Ben Aigan Hammer
Grade - **▲ DIFFICULT**
Wow. A knock-out from The Hammer. One long big hit ride around the summit of Ben Aigan with stunning views of the Spey valley, big earth features, and even board walk sections. Finish off with the Mast Blast or Bunny for the full Ben Aigan experience. (The trail is often affected by winter weather).

The Mast Blast
Grade - **◆ SEVERE**
A rushing downhill just beyond the big transmitter mast. Time to rock and roll! Deceptively speedy, with jumps. Check your speed and expect the unexpected. Spin City follow on: Hit the forest road and turn right. Don't miss the marker to take you off right to more single track switchbacks all the way back to the car park.

The Bunny
Grade - **● EXTREME**
What a thumper. Fast, free and furious, this trail has it all. Could it be the thinking rider's downhill? The name? Don't ask! When you hit the road, turn right, keep climbing... and link with Spin City section of Mast Blast.

Starting or finishing in Craigellachie
Starting - head up the Speyside Way into the forest past Anrdilly (but don't bring the car - there's no parking). Follow the waymarkers that climb steeply up to join the Hammer. Now you're up here - make a day of it!
Finishing - waymarkers point you off the south end of 'The Hammer' towards Craigellachie.

QUARRELWOOD
A taster easy cross country route, a short ride from Elgin. Practice your skills here and then head up to the main trails around Fochabers. This route is less formal than the main trails and for waymarkers you need to follow the white quartz rocks. Start in the Leggat car park - West end of the forest or from the Brumley Brae car park if you're cycling from Elgin. See map. This is a busy wood used by walkers so please keep everyone happy and follow the code.

ACKNOWLEDGEMENTS

Section A Question 2 – Page from Sainsbury's Magazine – “A little place we know – Casa Alla Scala, Sicily” (Page 135 of the Travel Section, Words: Sarah Randell, Photographs: Jan Baldwin). Published by Seven. Reproduced by kind permission of Seven.

Leaflet for use with Question 1 – Leaflet – Moray Monster Trails. Contains, or is based on, information supplied by the Forestry Commission. © Crown Copyright and database right (2014) Ordnance Survey (100021242).

Leaflet for use with Question 1 – Leaflet – Logo and reference to The Outdoor Access Code.

SQA has made every effort to trace the owners of copyright materials reproduced in this question paper, and seek permissions. We will be happy to incorporate any missing acknowledgements. Please contact Janine.Anderson@sqa.org.uk.