

STAPLE HERE

FOR OFFICIAL USE

--	--	--	--	--	--	--	--

**X033/12/01**

NATIONAL  
QUALIFICATIONS  
2014

THURSDAY, 8 MAY  
1.00 PM – 4.00 PM

GRAPHIC  
COMMUNICATION  
HIGHER

Fill in these boxes and read what is printed below.

Full name of centre			Town		
Forename(s)			Surname		
Date of birth	Day	Month	Year	Scottish candidate number	Number of seat
	<input type="text"/>	<input type="text"/>	<input type="text"/>	<input type="text"/>	<input type="text"/>

1 **140 Marks are allocated to this paper.** Section A = 40 marks  
Section B = 100 marks

- Candidates should attempt **all** questions in **Section A** and are advised to spend approximately 45 minutes on this section. A supplementary page is included at the end of **Section A** for use if extra space is required.
- Candidates should attempt questions 7a, 7b, 8, 9, 10 and **either** question 11 **or** question 12 in **Section B**.
- Read each question carefully before you answer.
- Written answers may be in **ink or pencil**.
- Drawings and sketches **must be in pencil**.
- Dimensions are given in millimetres or as stated.
- Orthographic drawings are in third angle projection.
- At the end of the examination**  
check that your name is on every sheet;  
put the sheets in correct numerical order;  
place this sheet on top of the others;  
join all sheets together by stapling at the top left-hand corner;  
before leaving the examination room, you must give these sheets to the Invigilator (if you do not you may lose all the marks for this paper).

Question	Marks
1	
2	
3	
4	
5	
6	
Section A Total	

**EITHER**  
**OR**

7a	
7b	
8	
9	
10	
11	
12	
Section B Total	

<b>Total Marks A + B</b>	
----------------------------------	--



[BLANK PAGE]

**1** *A supplementary page is included at the end of Section A for use if extra space is required.*

**2**

**Section A**

(a) State the desktop publishing DTP term for each of the descriptions given below. Marks

(i) A vertical line dividing two columns of text. 1

(ii) Text at the bottom of the page repeated throughout the document. 1

(iii) Text describing a graphic. 1

(iv) The term used to describe the size of a font. 1

(v) White text on a black background. 1

(b) A desktop publishing DTP document is planned in stages. Describe the purpose for each of the stages given below.

(i) Research 1

(ii) Thumbnails 1

(iii) Visuals 1

(a) A shape has been drawn using a CAD package. Marks

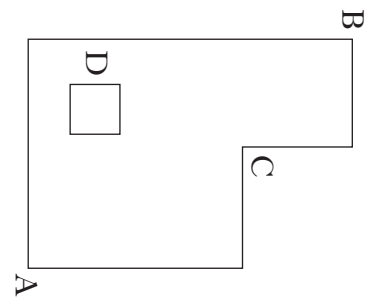

Sketch a new shape, after applying the following CAD commands.

(i) Rotate 90° clockwise using corner A as the pivot point; 1

(ii) Chamfer at B 4 × 4 mm approximately; 1

(iii) Fillet at C radius 5 mm approximately; 1

(iv) Rectangular array 2 by 2 on square D; 1

(v) Hatch one of the squares. 1

(b) State **one** benefit other than saving time of using the CAD feature, Library. (6)

**3**

(a) State the term given to the practice of applying an upper and lower limit from a nominal dimension when designing a component for manufacture. 1

(b) State **two** reasons why this practice is important in manufacturing. 1

(i) 1

(ii) 1

(8)

(3)

Candidate's Name \_\_\_\_\_

(a) State **three** factors that would influence the scale of a drawing.

Marks

(i) .....

1

(ii) .....

1

(iii) .....

1

(b) What effect would the following scales have on a drawing.

(i) 2:1 .....

1

(ii) 1:2 .....

1

(c) Drawing sheets are usually presented in one of two orientations.

Sketch each orientation and state which orientation they are.

(i) Sketch

Orientation .....

1

(ii) Sketch

Orientation .....

1

(7)

The 3Ps are used extensively in the design, manufacture and marketing within the construction industry.

Marks

Identify the type, and explain the purpose of each of the 3Ps shown below.

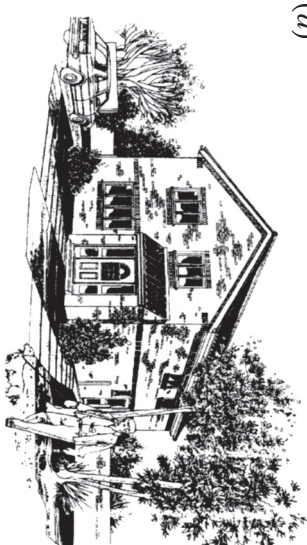

(a)

Type

..... 1

Purpose

.....

..... 1

(b)

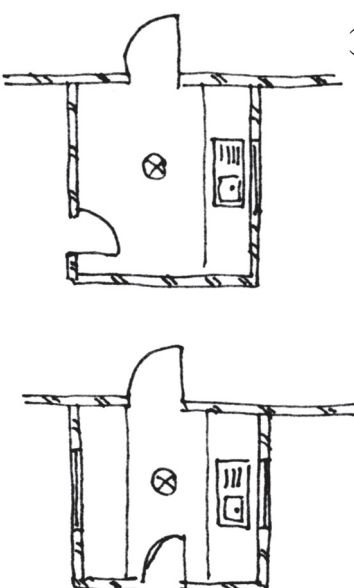

Alternative designs for extension

Type

..... 1

Purpose

.....

..... 1

(c)

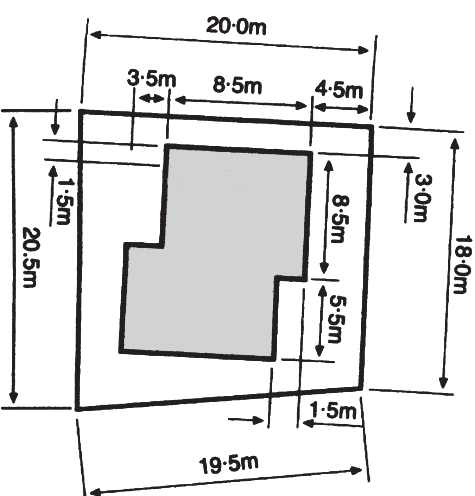

Type

..... 1

Purpose

.....

..... 1

(6)

- (a) State the main reason for the use of British Standards conventions on drawings. Marks  
 ..... 1
- (b) State the names of the British Standard conventions shown below.

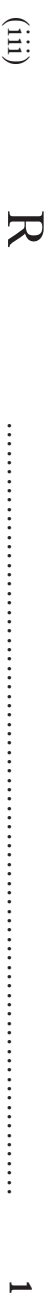
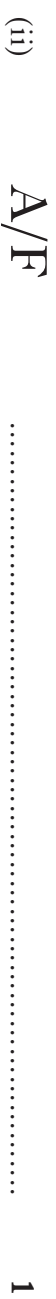
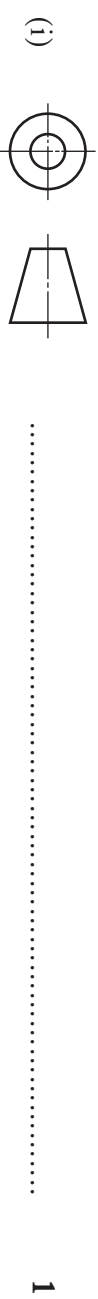

- (d) Sketch on the drawing below, using British Standard conventions. Marks
- (i) The metric thread diameter 12 mm on the elevation. 1
- (ii) The flat surface at the right hand end of the component. 1
- (iii) The external thread detail on the end elevation. 1

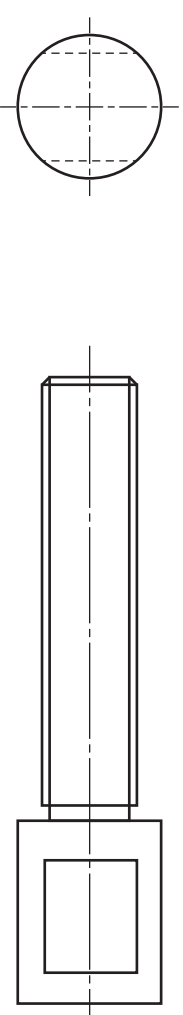

END ELEVATION

ELEVATION

(10)

- (c) State the names of the **two** types of sections shown at **X** and **Y-Y** on the drawing shown below.

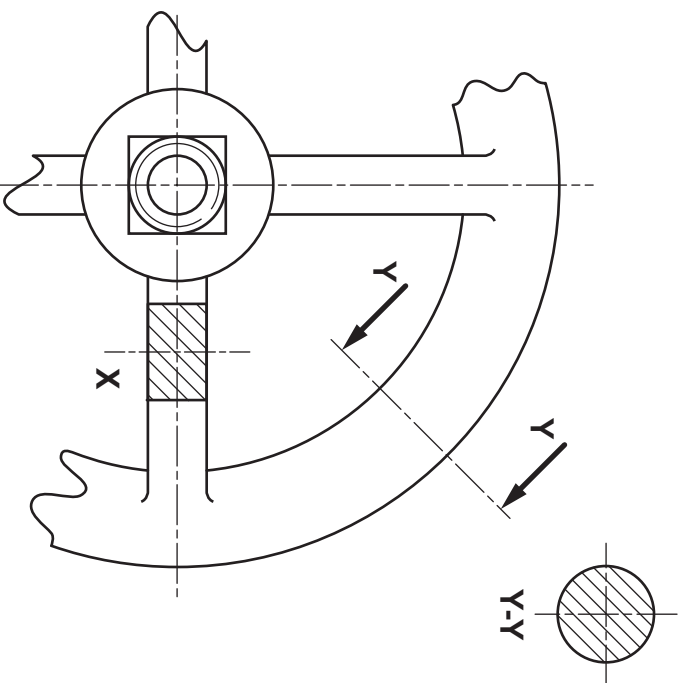

X ..... 1

Y-Y ..... 1

**SUPPLEMENTARY PAGE**

**Section A**

Use this page if extra space is required for answers to Questions 1 to 6.

**Number each answer clearly.**

The plan of a visitors centre is given to a scale of 1:50. It is proposed to build an extension, external dimensions 4 metres x 3 metres onto the East facing wall. An architect has prepared a sketch of the proposed extension.

Draw:

- (i) the extension, including the fittings, from instructions shown on the sketch;
- (ii) the hatching of brickwork on the extension;
- (iii) the two external dimensions of the extension to British Standards.

Use the British Standard Symbols given below.

(10 marks)

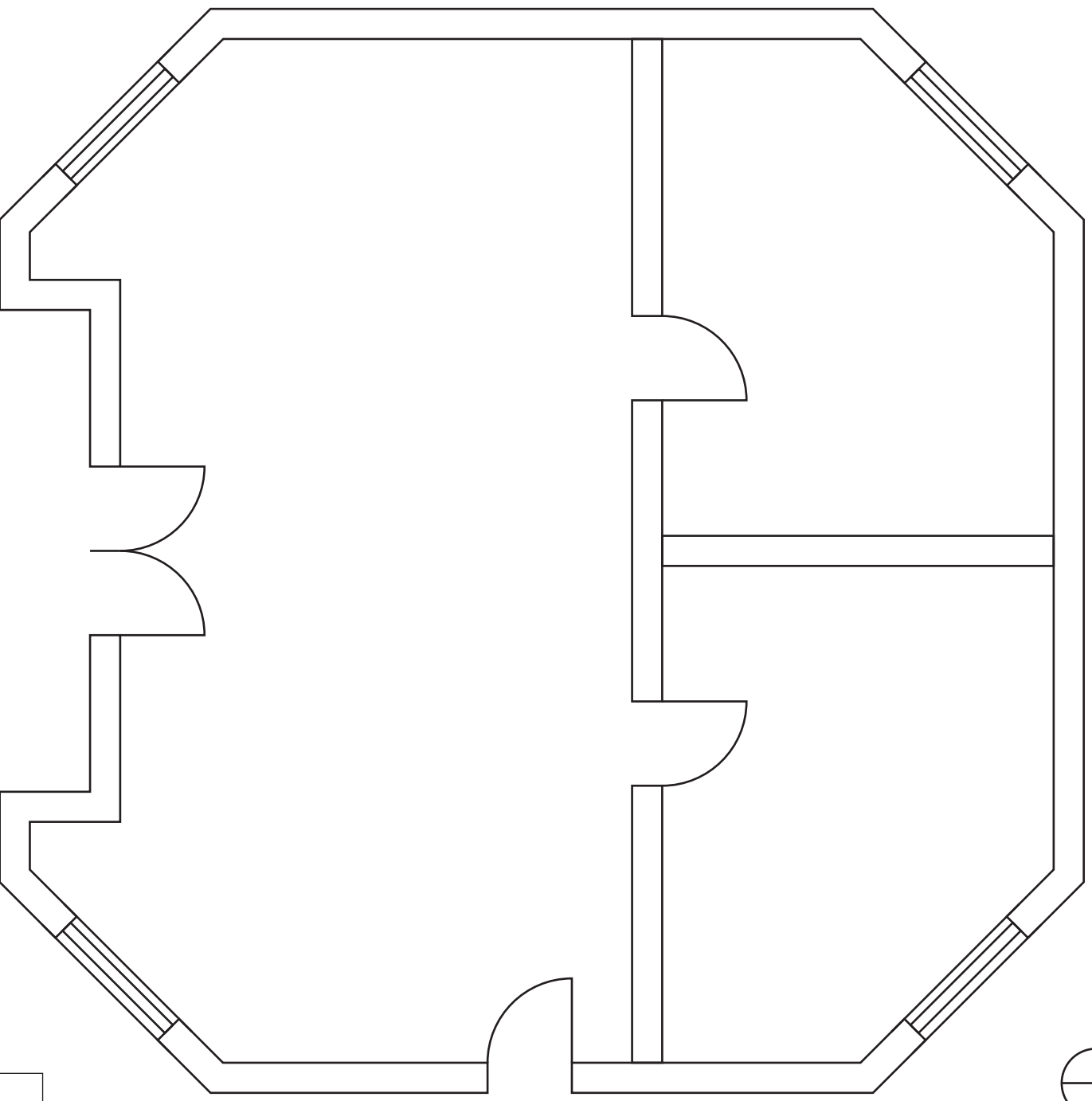

PLAN

SCALE 1:50

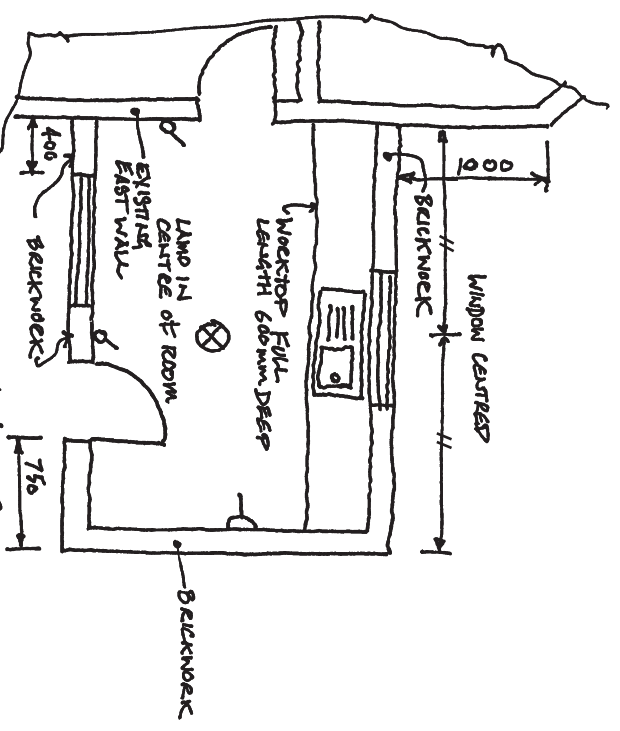

Architects Sketch  
(NOT TO SCALE)

BRITISH STANDARDS SYMBOLS

	Window		Socket		Door		Sinktop		Switch		Lamp		Brickwork hatching
--	--------	--	--------	--	------	--	---------	--	--------	--	------	--	--------------------

a	
b	
c	
d	
e	
f	
g	
h	
i	
j	
k	
l	
m	
n	

The plans and elevation of the visitors centre shown in **7a** are given.

**Draw** a measured 2-point perspective view of the visitors centre.

The Spectator Point (SP), Plane of Projection (PP), Ground Line (GL), Eye Level (EL) and plan to the same scale are given.

**Do not show hidden detail.** (20 marks)

EL \_\_\_\_\_

\_\_\_\_\_

GL \_\_\_\_\_

\_\_\_\_\_

PP \_\_\_\_\_

\_\_\_\_\_

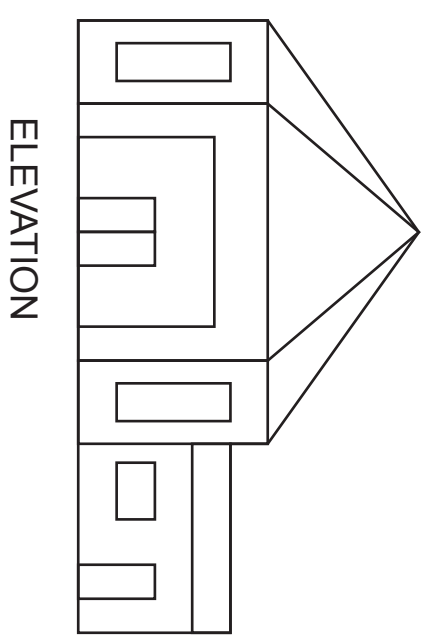
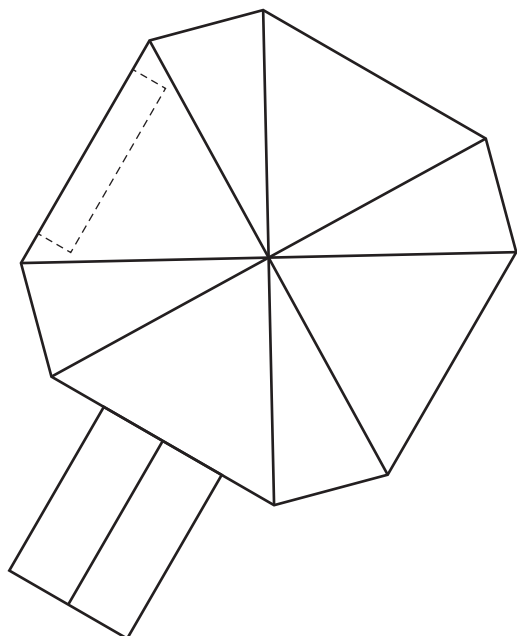
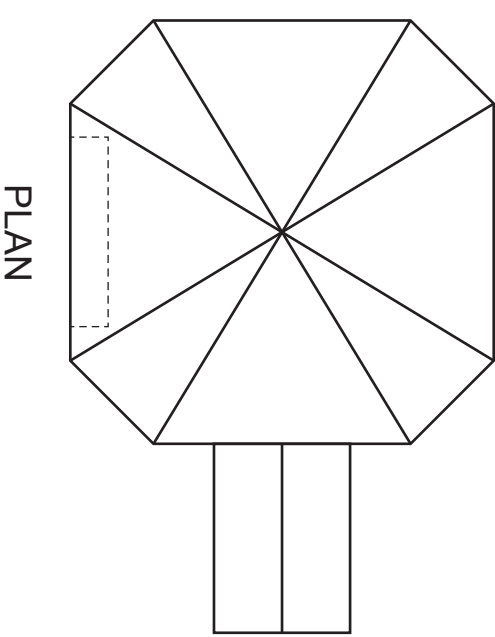

a	
b	
c	
d	
e	
f	
g	
h	
i	
j	
k	
l	
m	
n	

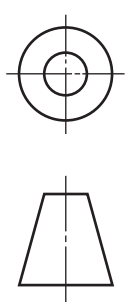



The plan, elevation and end elevation of a bar box are given.

**Draw**, full size and in the position indicated an **auxiliary plan** of the bar box.

(**Note:** The small hole should be accurately located but may be sketched.)

**Do not show hidden detail.**

**(14 marks)**

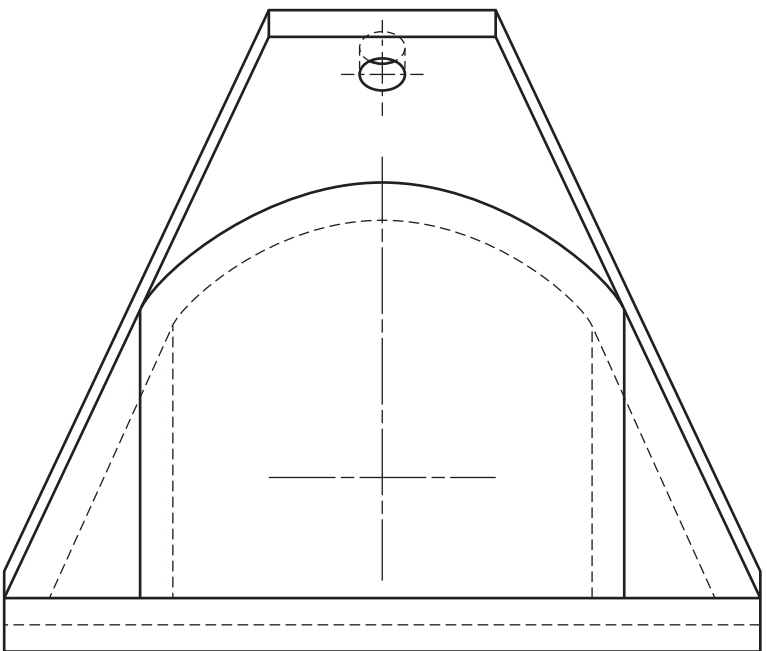

PLAN

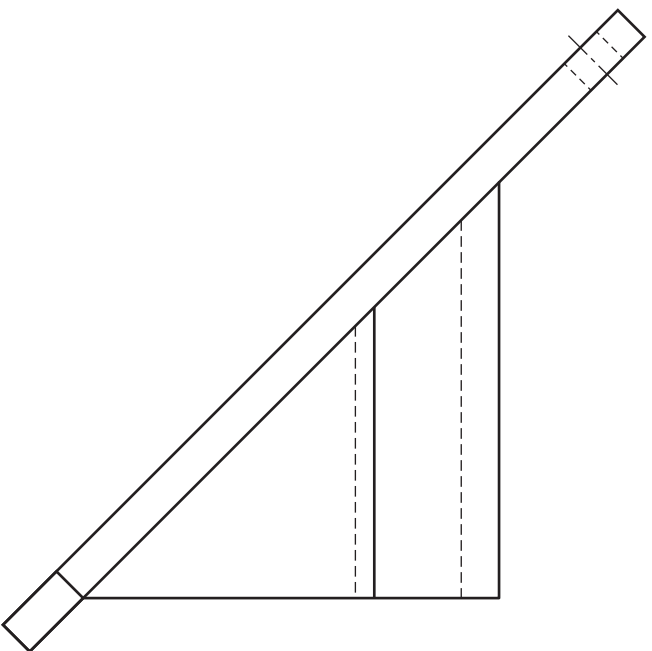

ELEVATION

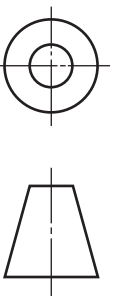

[X033/12/01]

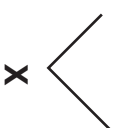

AUXILIARY  
PLAN

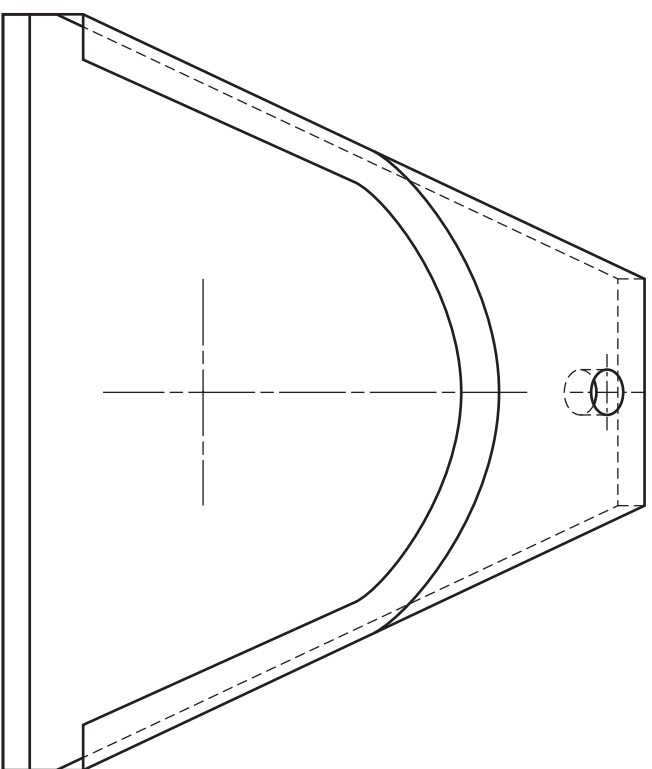

END ELEVATION

a	
b	
c	
d	
e	
f	
g	
h	
i	
j	
k	
l	
m	
n	

Candidate's Name \_\_\_\_\_

Orthographic views of the five parts that make up a watch clamp are given below.  
The assembled elevation and incomplete plan are also given on **Worksheet Question 9**.

**Draw** in the positions indicated on **Worksheet Question 9**:

(a) the complete plan;  
**Show hidden detail.**

(b) a sectional end elevation on **A-A**.  
**Do not section the bolt and do not show hidden detail.**

(All fillets may be drawn freehand.)

(25 marks)

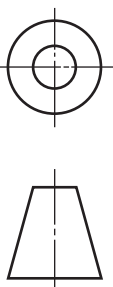
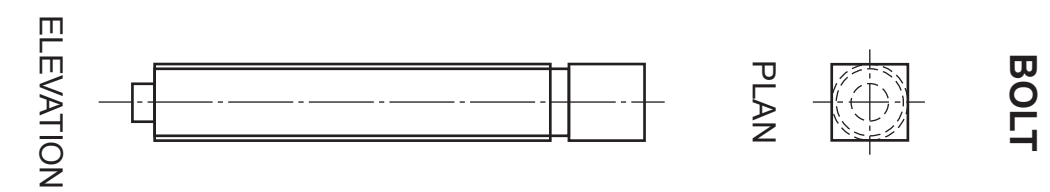
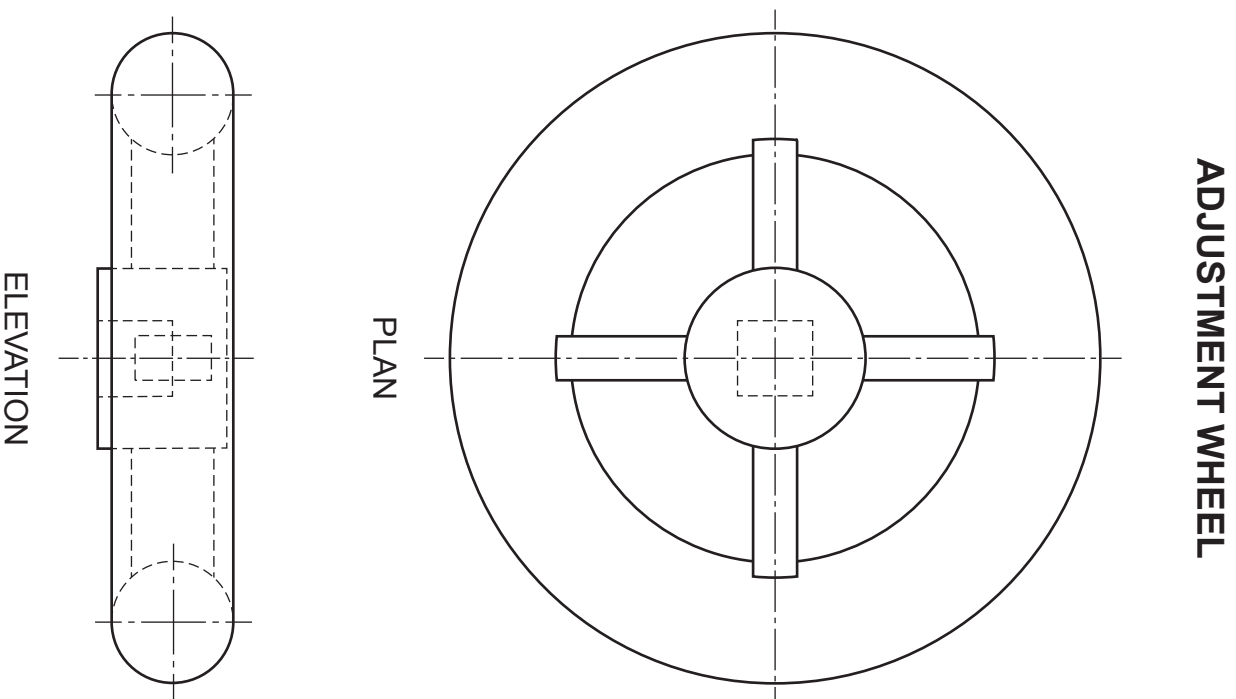
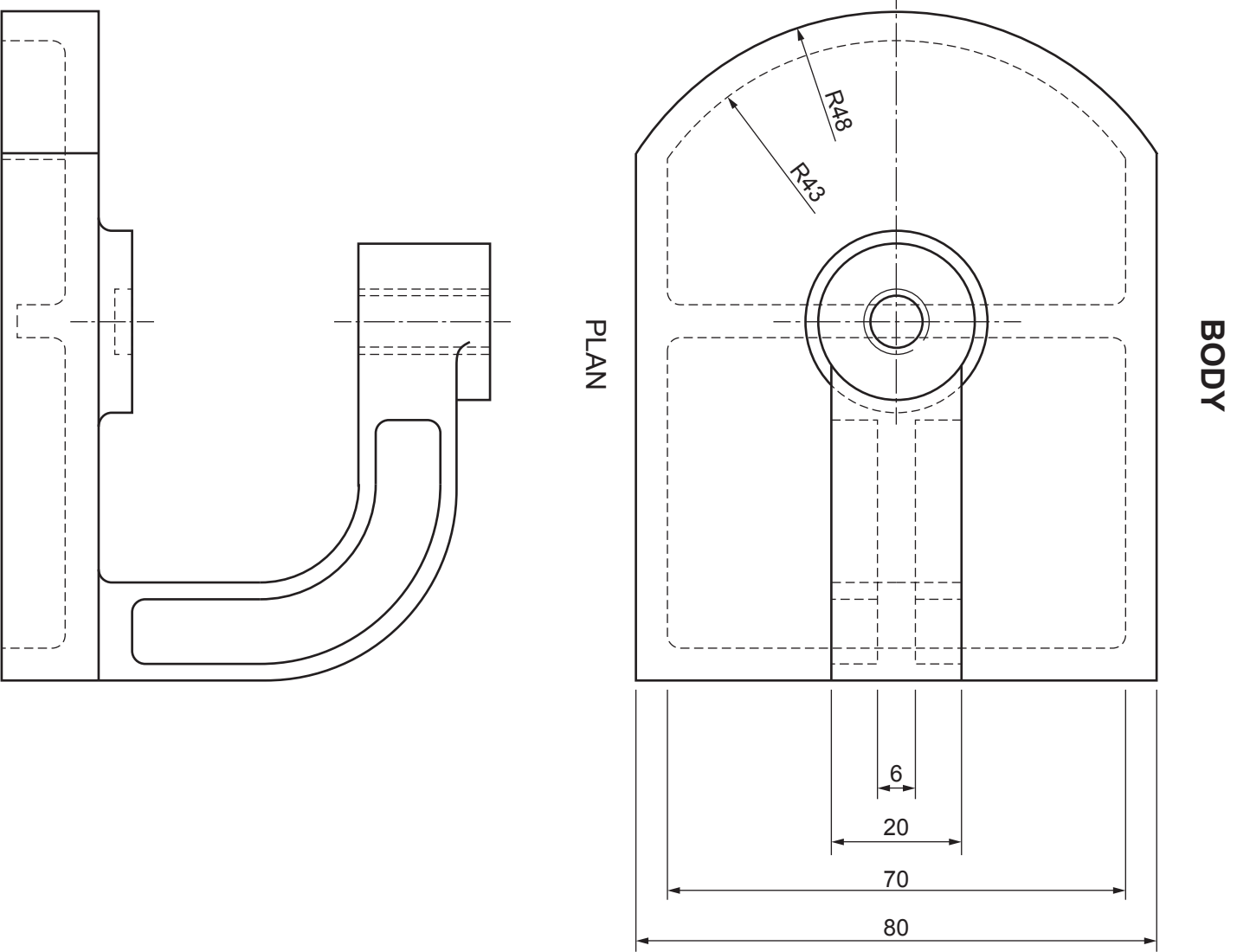

NOT TO SCALE

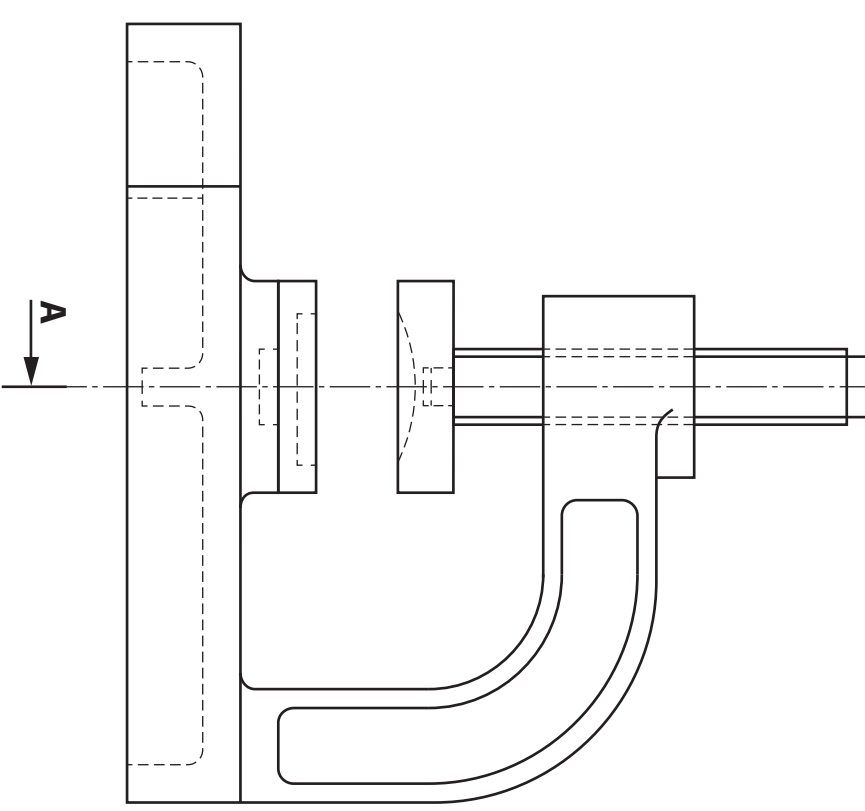
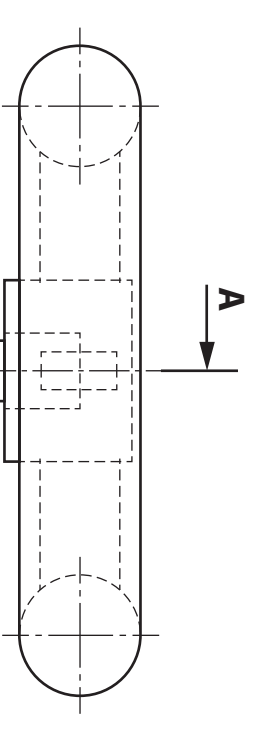
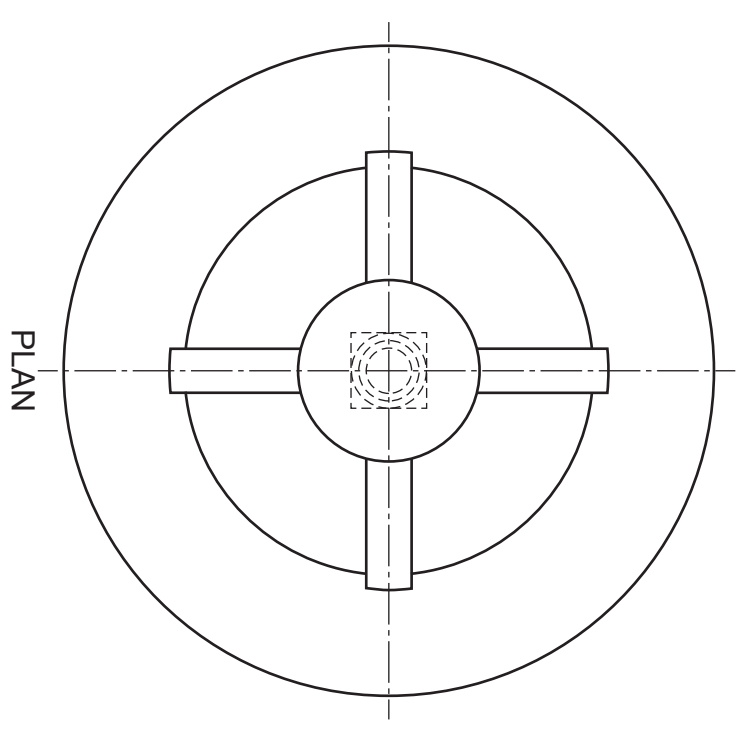

-----

SECTIONAL END ELEVATION A-A

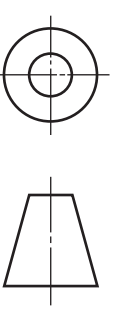

[X033/12/01]

ELEVATION

<i>a</i>	
<i>b</i>	
<i>c</i>	
<i>d</i>	
<i>e</i>	
<i>f</i>	
<i>g</i>	
<i>h</i>	
<i>i</i>	
<i>j</i>	
<i>k</i>	
<i>l</i>	
<i>m</i>	
<i>n</i>	

Candidate's Name \_\_\_\_\_

The elevation and end elevation of a wall light are given.  
A pictorial view is also shown.

**Draw**, to the same scale:

- (a) a **plan** in the position indicated showing the lines of intersection;
- (b) a **development** of the connecting piece.

The start **A** is given.

**(11 marks)**

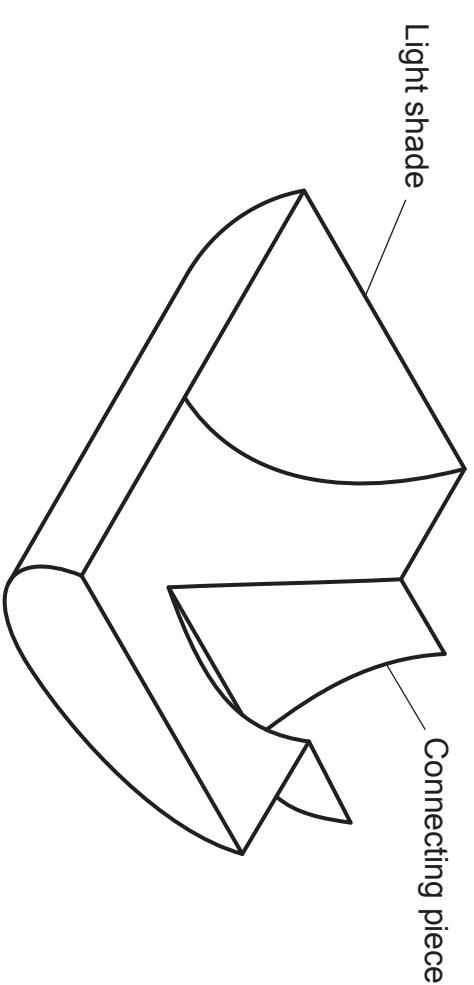

PICTORIAL VIEW  
(not to scale)

a	
b	
c	
d	
e	
f	
g	
h	
i	
j	
k	
l	
m	
n	

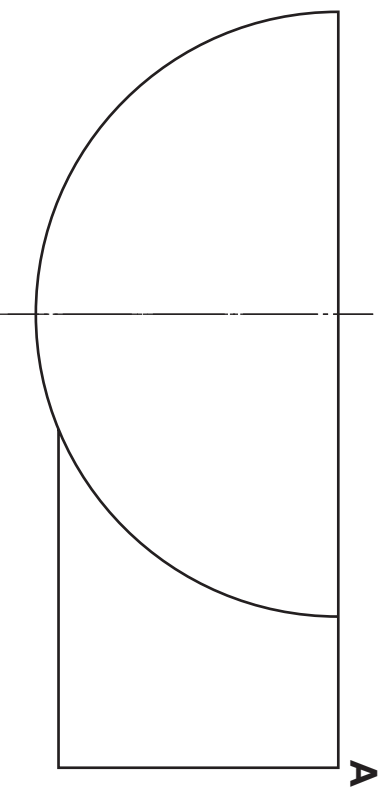

END ELEVATION

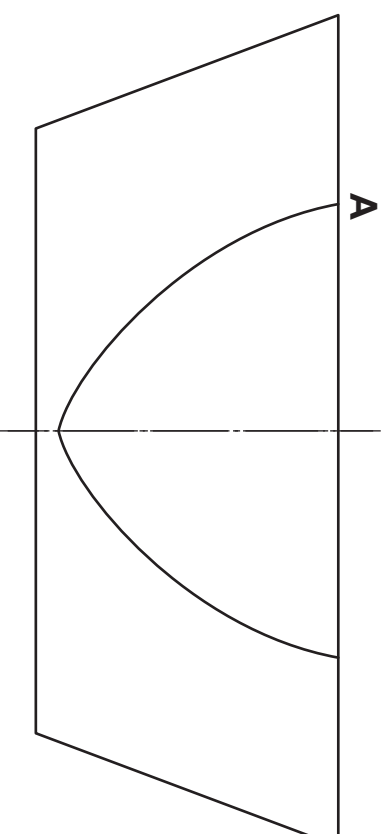

ELEVATION

PLAN



DEVELOPMENT

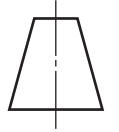
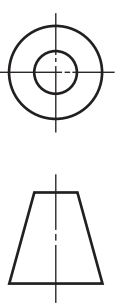



The elevation and end elevation of a petrol pump handle are given.

Draw an isometric view of the pump handle in the position indicated.

Do not show hidden detail.

(20 marks)

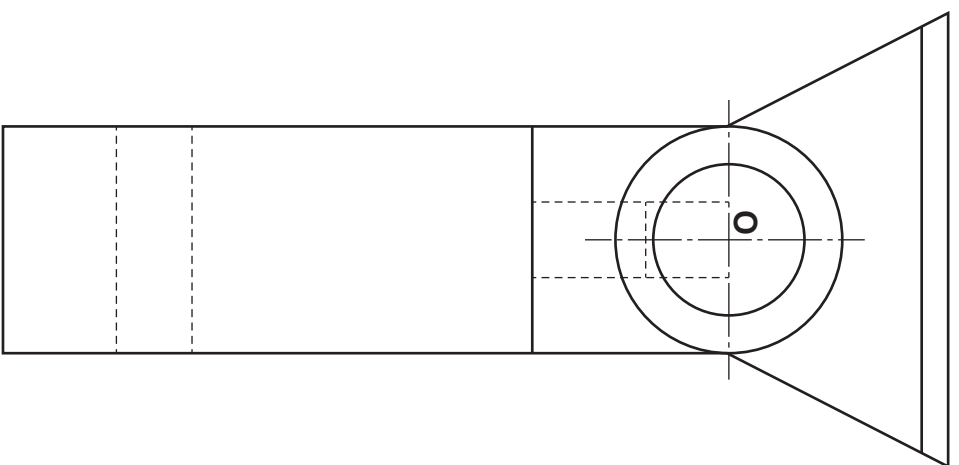
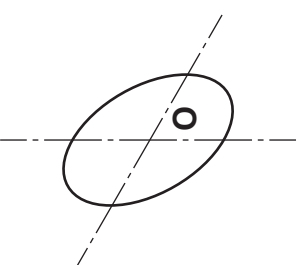

END ELEVATION

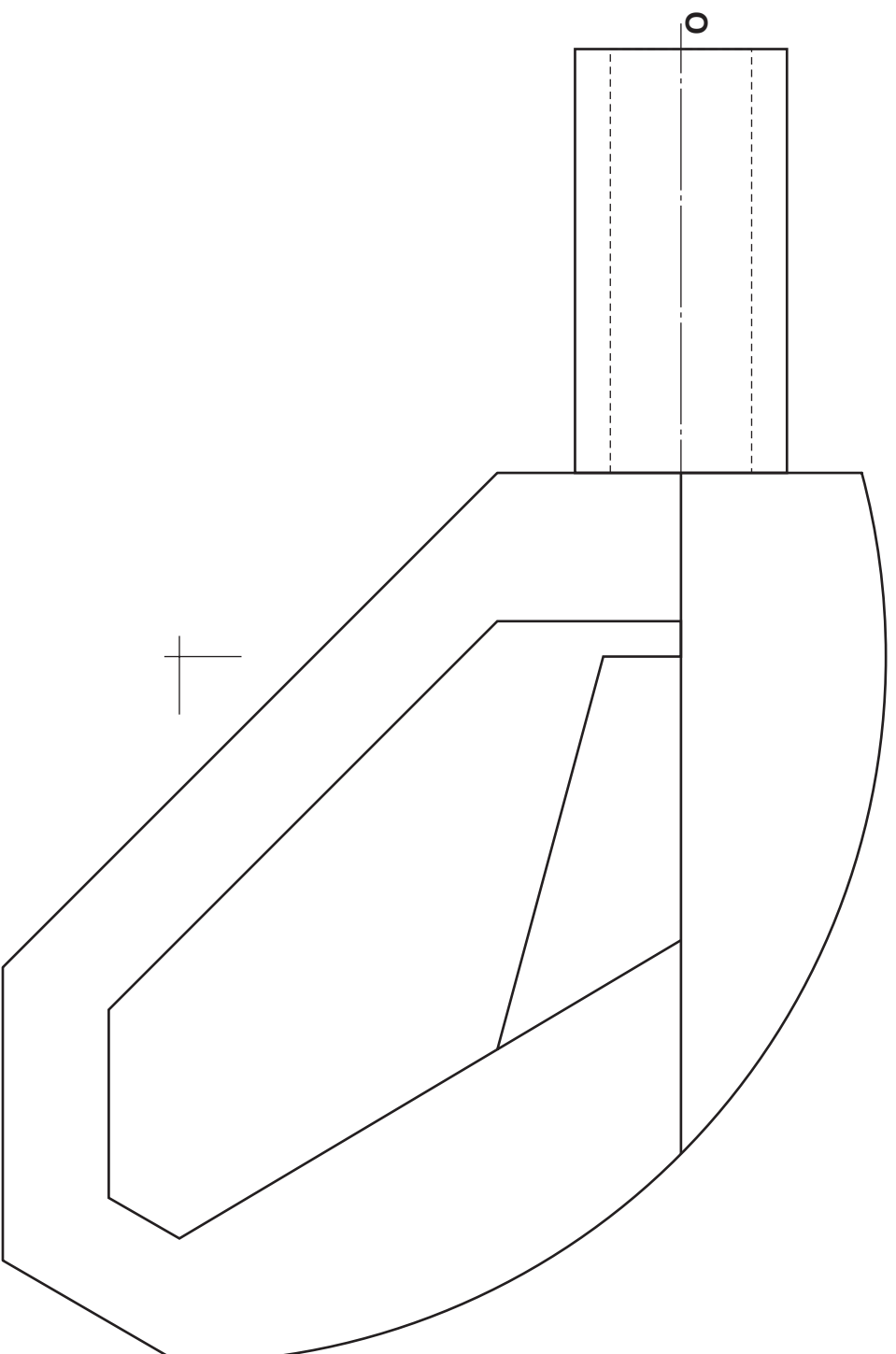

ELEVATION

ISOMETRIC

a	
b	
c	
d	
e	
f	
g	
h	
i	
j	
k	
l	
m	
n	

