

STAPLE HERE

FOR OFFICIAL USE

--	--	--	--	--	--

## X033/12/01

NATIONAL  
QUALIFICATIONS  
2012

FRIDAY, 18 MAY  
9.00 AM – 12.00 NOON

GRAPHIC  
COMMUNICATION  
HIGHER

Fill in these boxes and read what is printed below.

Full name of centre

Town

Forename(s)

Surname

Date of birth

Day Month Year

Scottish candidate number

Number of seat

- 1 **140 Marks are allocated to this paper. Section A = 40 marks  
Section B = 100 marks**
- 2 Candidates should attempt **all** questions in **Section A** and are advised to spend approximately 45 minutes on this section. A supplementary page is included at the end of **Section A** for use if extra space is required.
- 3 Candidates should attempt questions 7, 8, 9, 10 and **either** question 11 **or** question 12 in **Section B**.
- 4 Read each question carefully before you answer.
- 5 Written answers may be in **ink** or **pencil**.
- 6 Drawings and sketches **must be in pencil**.
- 7 Dimensions are given in millimetres or as stated.
- 8 Orthographic drawings are in third angle projection.
- 9 **At the end of the examination**  
check that your name is on every sheet;  
put the sheets in correct numerical order;  
place this sheet on top of the others;  
join all sheets together by stapling at the top left-hand corner;  
before leaving the examination room, you must give these sheets to the Invigilator (if you do not you may lose all the marks for this paper).

Question	Marks
1	
2	
3	
4	
5	
6	
Section A Total	

7	
8	
9	
10	
11	
12	
Section B Total	

EITHER  
OR

<b>Total Marks A + B</b>	
----------------------------------	--



**[BLANK PAGE]**

1 A supplementary page is included at the end of Section A for use if extra space is required.

(a) Shown below are the stages used in drawing the plan of a microchip using a CAD package. State the **single** CAD command used at each stage. Marks

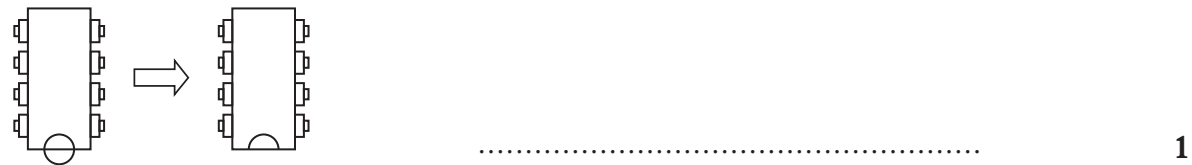
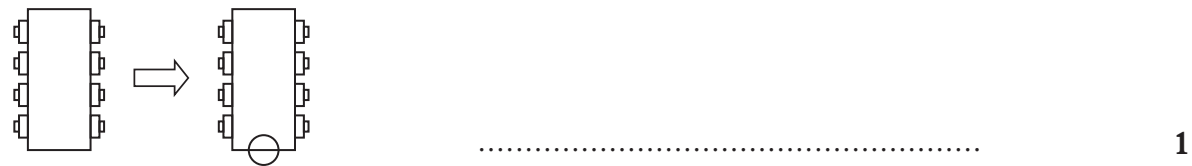

(b) (i) State the CAD feature which allows the drawing of the microchip to be saved and used in other circuit diagrams.

..... 1

(ii) State **one** advantage other than time of using this CAD feature.

..... 1

(c) (i) State the CAD feature which allows the connections to be revealed or concealed.

..... 1

(ii) State **one** advantage other than time of using this CAD feature.

..... 1

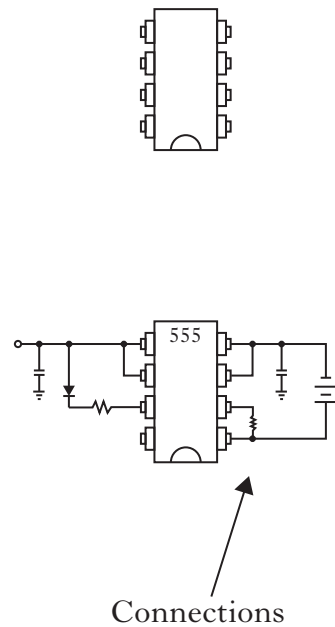

1

(8)

2

(a) State the **two** types of dimensioning shown below at A and B. Marks

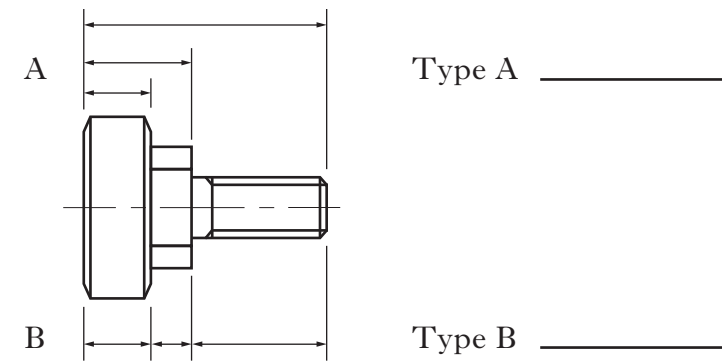

2

(b) In order to manufacture the component, accurate functional tolerances will have to be applied. Explain why Type A would be preferable.

.....

.....

..... 1

(c) Sketch on the elevation below, to British Standards convention:

- (i) the 4 dimensions shown on the pictorial view; 4
- (ii) the flat surface. 1

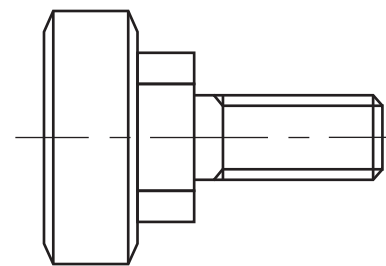

ELEVATION

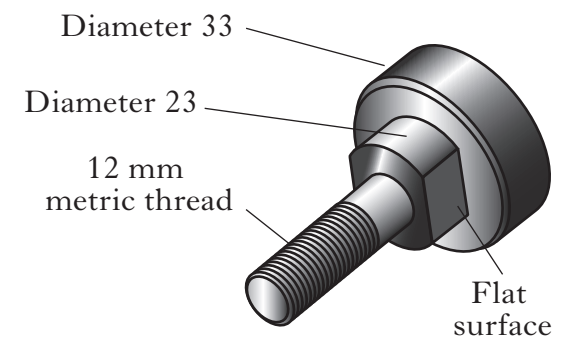

Overall length 50

(8)

Candidate's Name \_\_\_\_\_

3

(a) There are three stages in planning a DTP document prior to the production of the final electronic version. Research is the first stage.

State **two** further stages in planning a DTP document.

Stage .....

Stage .....

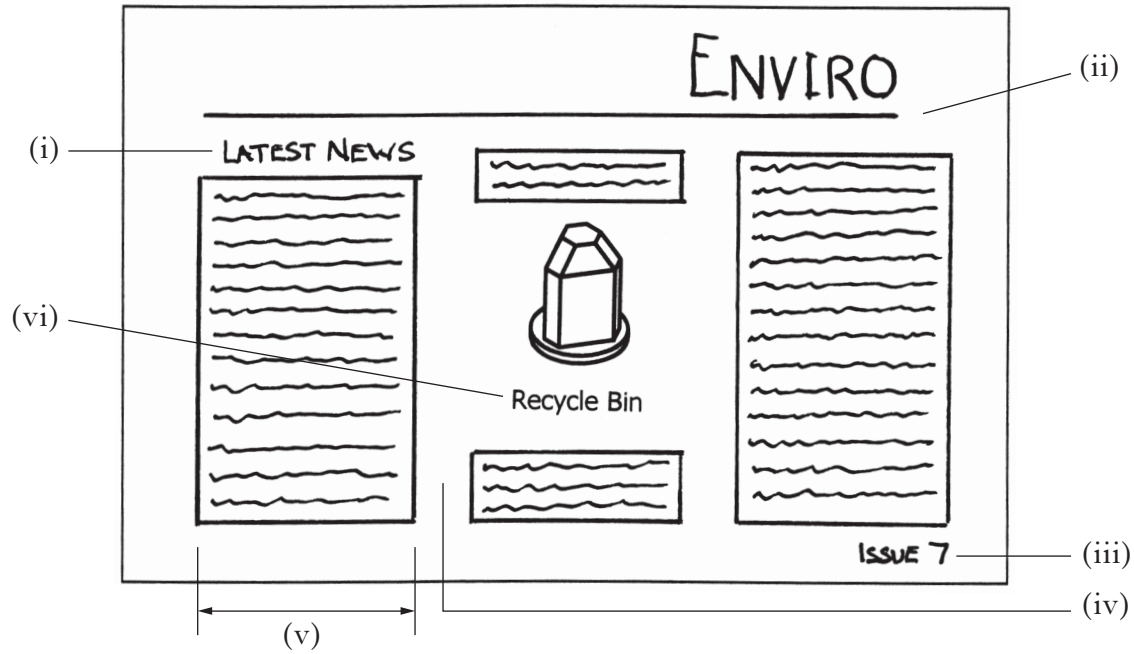

Part of the planning stage is shown above.

(b) State the page orientation used in the document above.

..... 1

(c) State the DTP term for the deliberately created clear area to the left of the word ENVIRO.

..... 1

(d) State the DTP term for each of the features (i) to (vi).

(i) ..... (ii) .....

(iii) ..... (iv) .....

(v) ..... (vi) .....

6  
(10)

4

A **Site Plan** is shown below, not to scale.

Section A

Marks

2

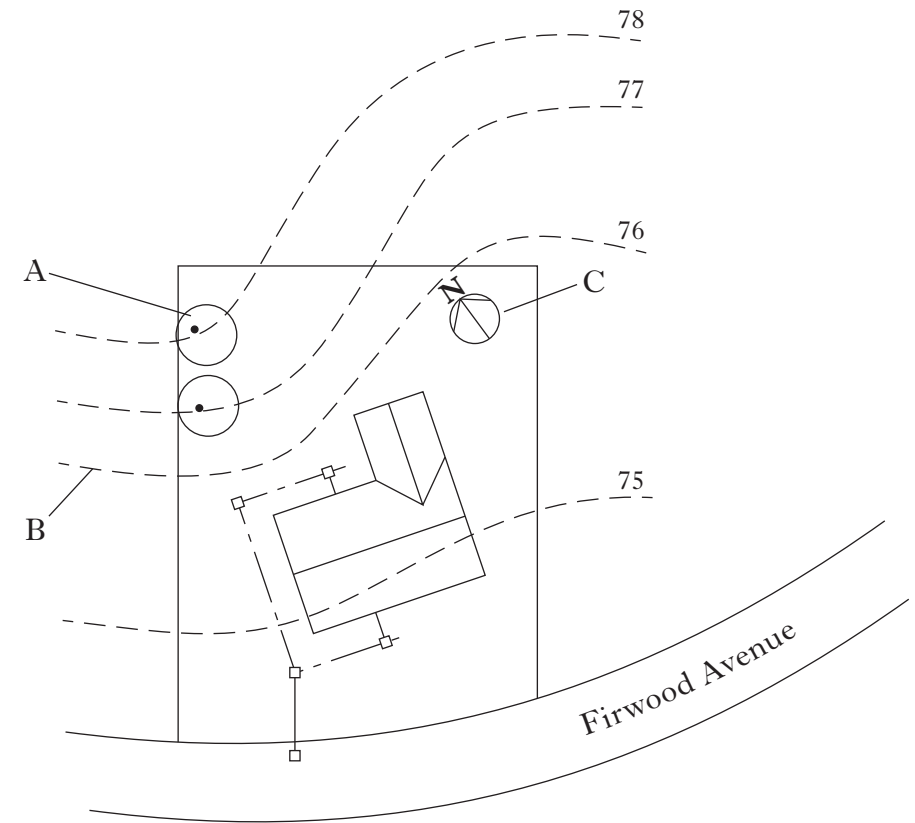

(a) State a suitable scale for this type of plan.

..... 1

(b) State the name of the British Standards (BSI) architectural symbols represented at A, B and C.

A .....

B .....

C .....

3

(c) State the name of **one** other type of architectural building plan.

..... 1  
(5)

5

(a) A drawing contains both a centre line and a visible outline located in the same position. State, according to British Standards, which would be given priority and drawn.

Marks

..... 1

(b) The following line descriptions are taken from British Standards. State the applications for each.

**Line Descriptions**

**Applications**

Dashed thin line

.....

.....

Chain thin double dashed

.....

.....

Continuous thin straight with zigzags

.....

.....

Continuous thin

.....

.....

4

(5)

**Section A**

6

(a) State the type of section produced by the three cutting planes shown below.

Marks

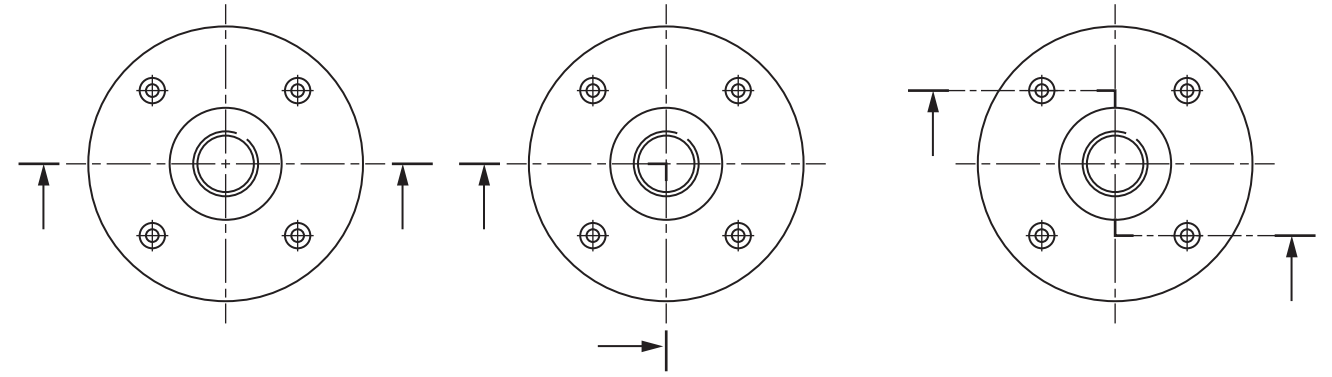

(i) ..... (ii) ..... (iii) ..... 3

(b) State the purpose of producing a section drawing.

.....

.....

1

(4)

Use this page if extra space is required for answers to Questions 1 to 6.

**Number each answer clearly.**

The profile of seating used in a modern bus shelter is shown.

**Draw** the outline of the seating on the given start X to a scale of 1:1.

Show clearly the centres used to draw all arcs.

**Do not show dimensions.**

**(10 marks)**

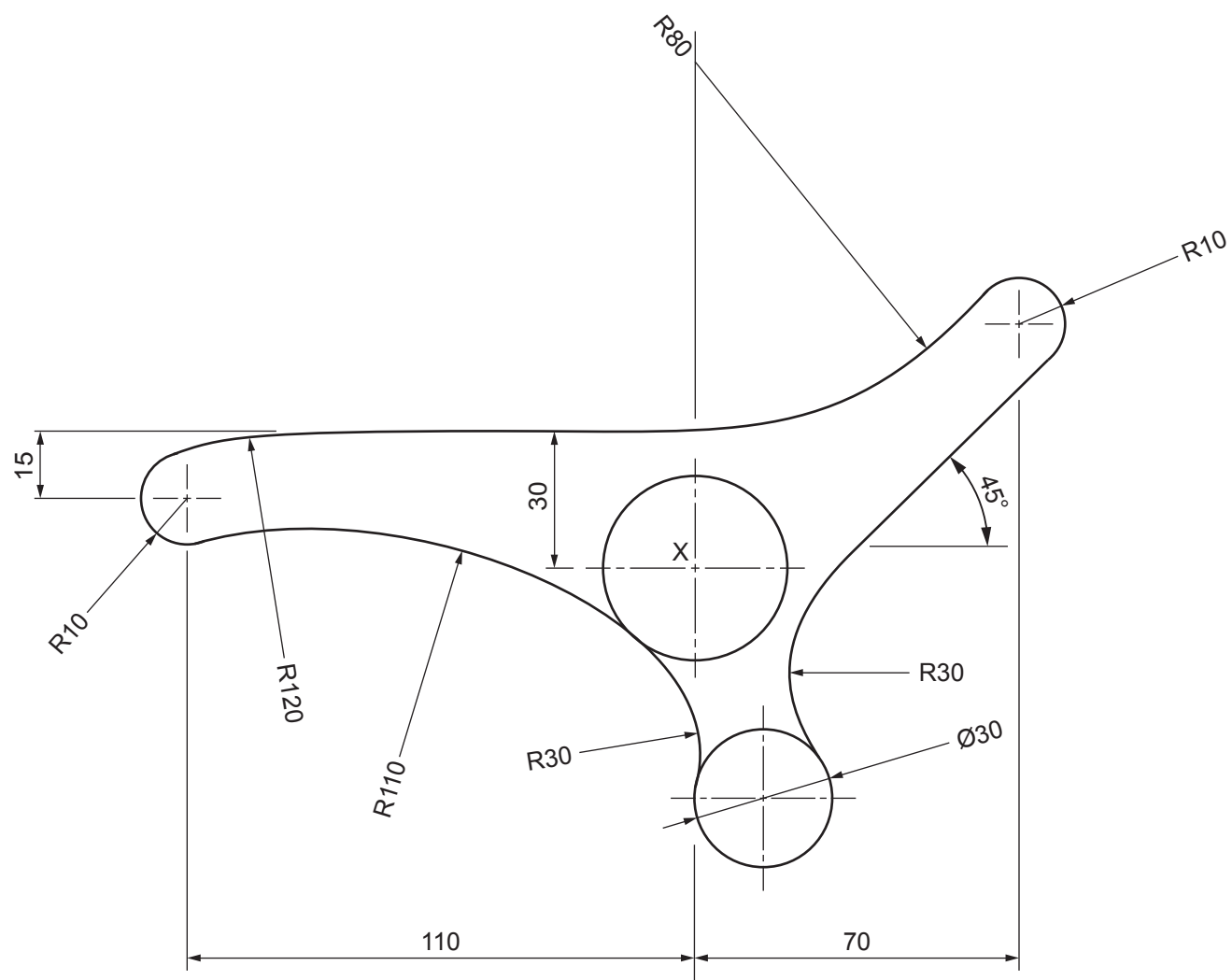

NOT TO SCALE

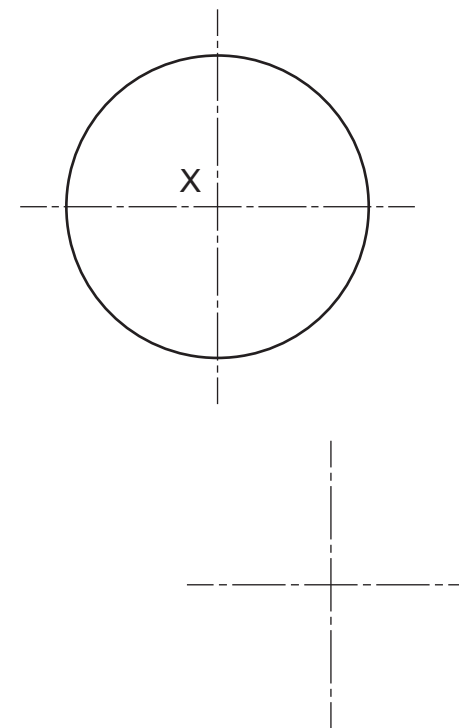

a	
b	
c	
d	
e	
f	
g	
h	
i	
j	
k	
l	
m	
n	

The elevation and end elevation of a cottage are given.

Draw a measured **2-point perspective** of the cottage.

The spectator point (**SP**), plane of projection (**PP**), ground line (**GL**), eye level (**EL**) and plan to the same scale are given.

**Do not show hidden detail.**

**(20 marks)**

**EL** \_\_\_\_\_

**GL** \_\_\_\_\_

**PP** \_\_\_\_\_

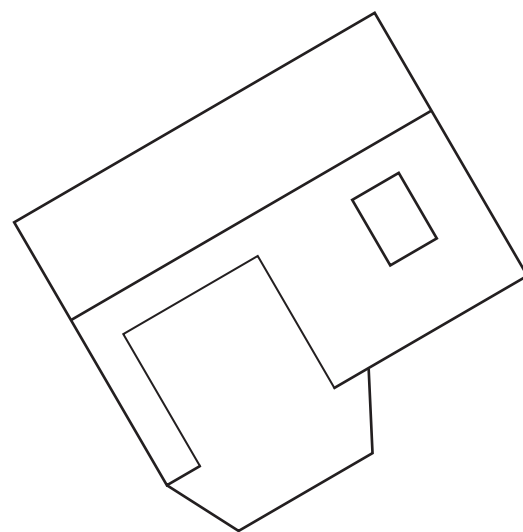

PLAN

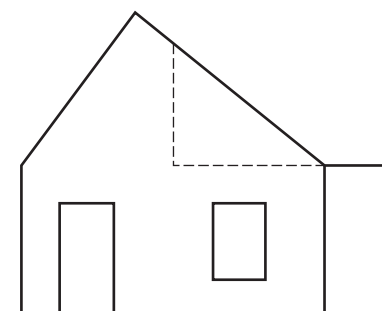

END ELEVATION

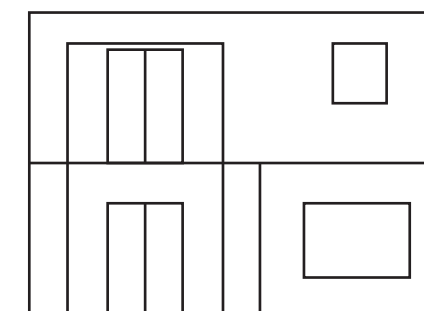

ELEVATION

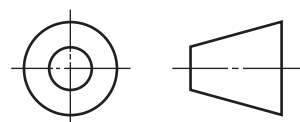

<i>a</i>	
<i>b</i>	
<i>c</i>	
<i>d</i>	
<i>e</i>	
<i>f</i>	
<i>g</i>	
<i>h</i>	
<i>i</i>	
<i>j</i>	
<i>k</i>	
<i>l</i>	
<i>m</i>	
<i>n</i>	



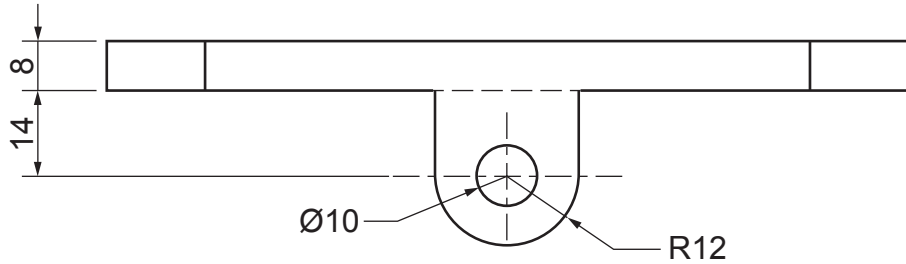
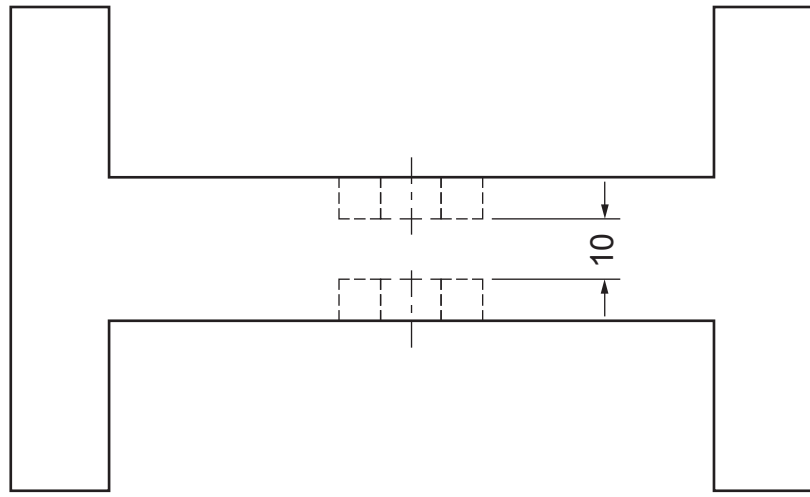

PLATFORM

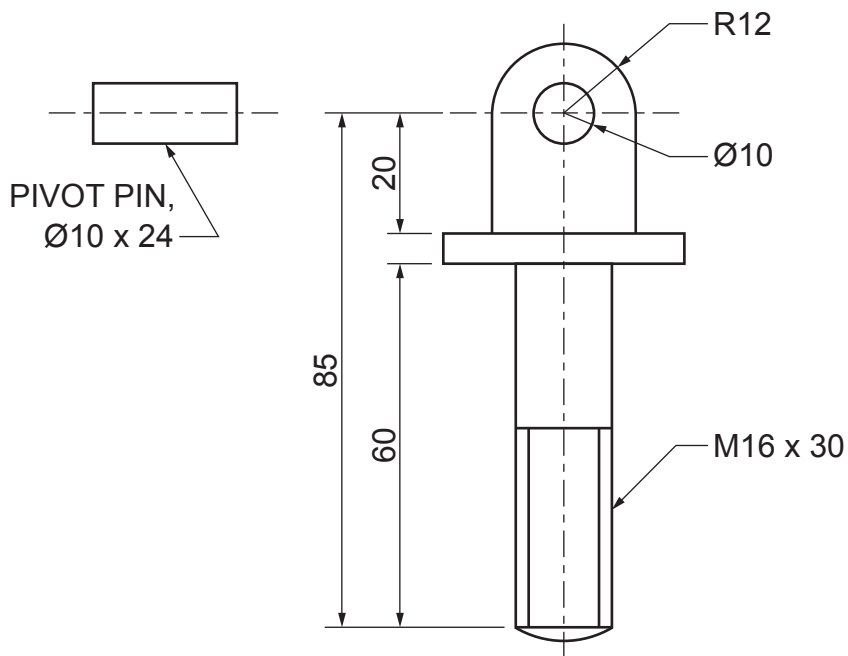
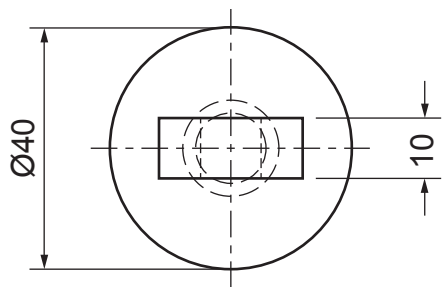

SWIVEL PIN

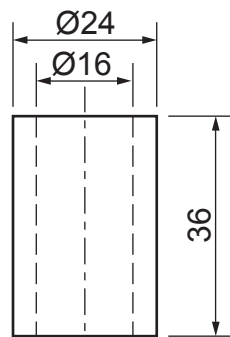

BUSH



M16 WASHER

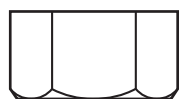

M16 NUT

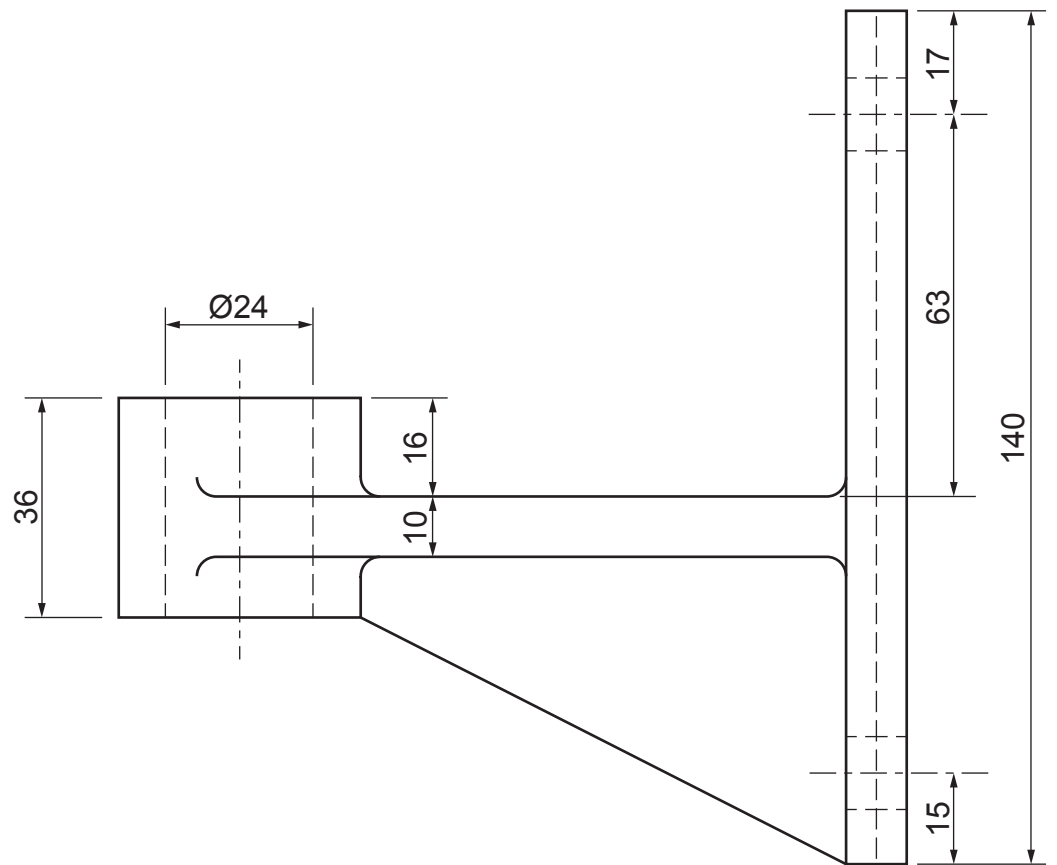
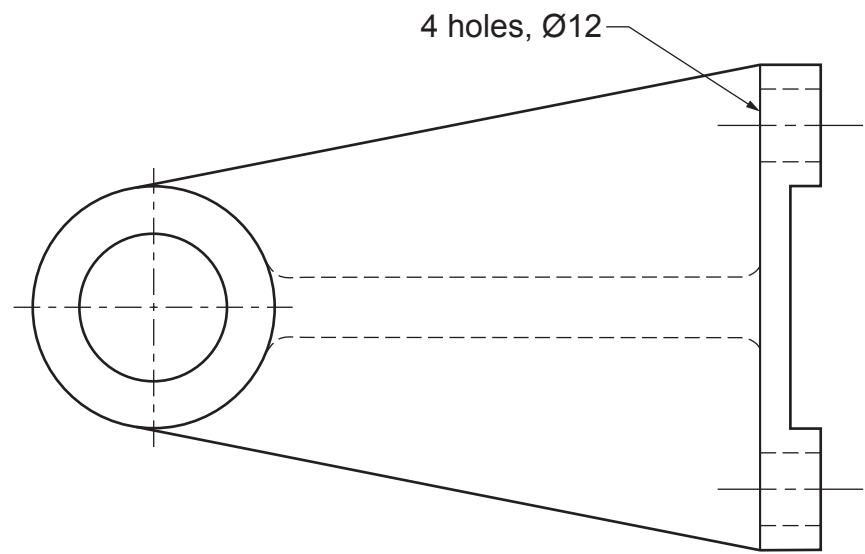

WALL BRACKET

The plan and elevation of each part of a CCTV support are shown.

The assembled plan, nut and washer are given on **Worksheet Question 9**.

**Draw**, in the positions indicated on **Worksheet Question 9**:

(a) the sectional elevation of the assembled components on **A-A**;  
**Do not show hidden detail.**

(b) the end elevation of the assembled components.  
**Show all hidden detail.**

**Note:** Do not section the **pivot pin** or the **swivel pin**.  
Fillets should be drawn freehand.

**(30 marks)**

**NOT TO SCALE**

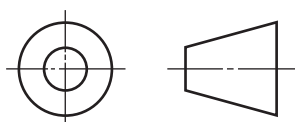

**[BLANK PAGE]**

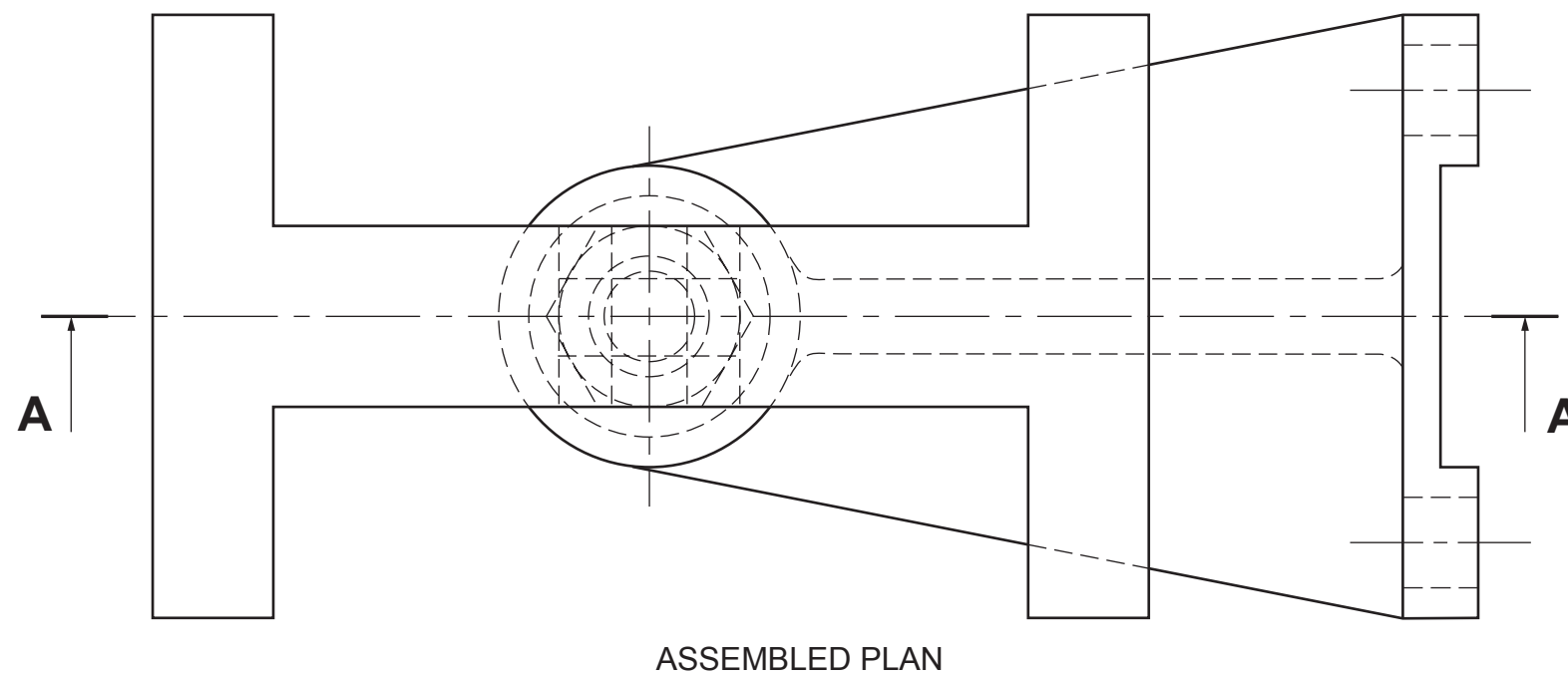

<i>a</i>	
<i>b</i>	
<i>c</i>	
<i>d</i>	
<i>e</i>	
<i>f</i>	
<i>g</i>	
<i>h</i>	
<i>i</i>	
<i>j</i>	
<i>k</i>	
<i>l</i>	
<i>m</i>	
<i>n</i>	

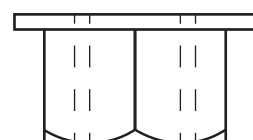

END ELEVATION

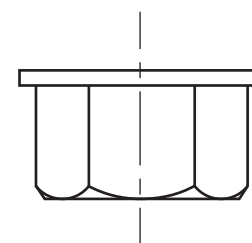

SECTIONAL ELEVATION ON A-A

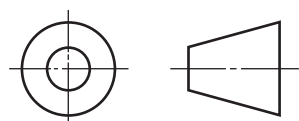

Candidate's Name \_\_\_\_\_

The elevation and end elevation of the top detail of a stair banister are given. An exploded pictorial view is also shown.

Using the given start at A-B, draw an exploded isometric view of the post, rail and pin.

Do not show hidden detail.

(20 marks)

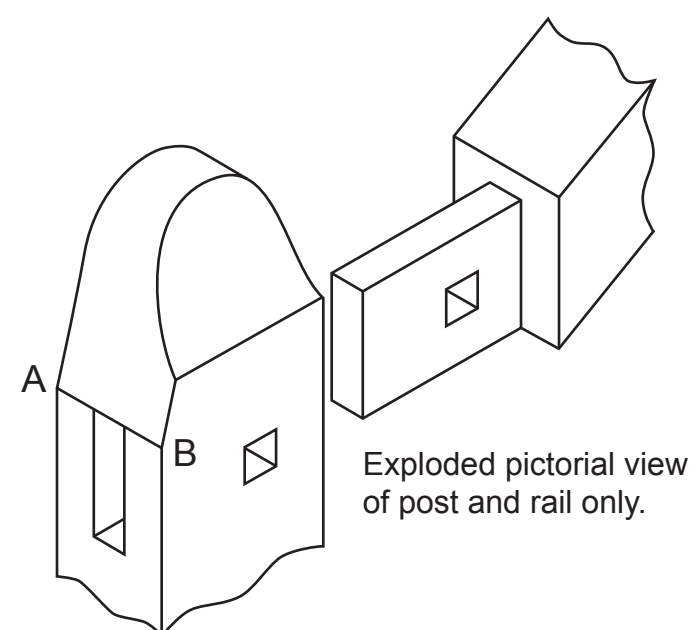
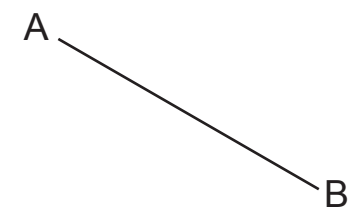
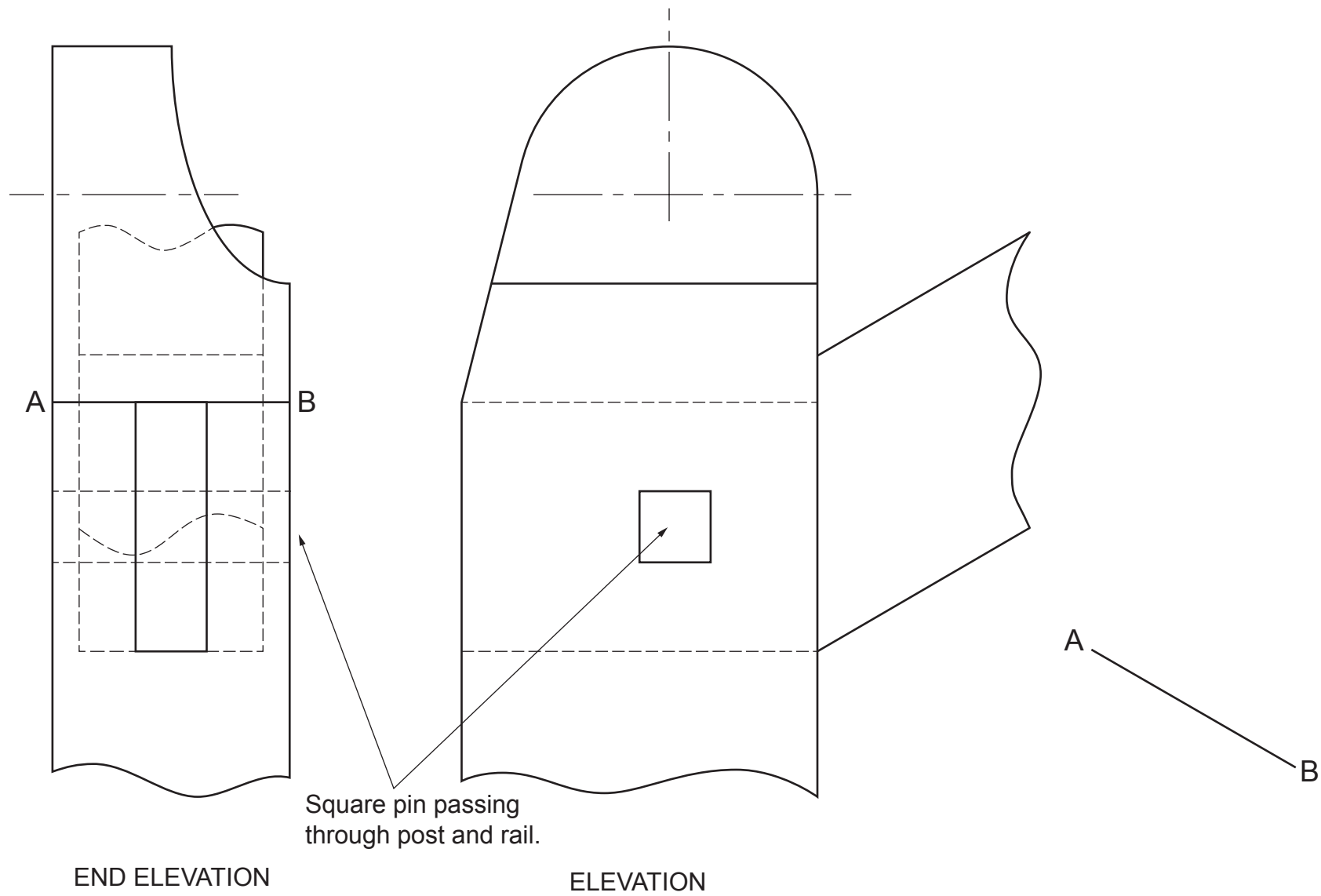

EXPLODED ISOMETRIC

<i>a</i>	
<i>b</i>	
<i>c</i>	
<i>d</i>	
<i>e</i>	
<i>f</i>	
<i>g</i>	
<i>h</i>	
<i>i</i>	
<i>j</i>	
<i>k</i>	
<i>l</i>	
<i>m</i>	
<i>n</i>	

11

Candidates should attempt EITHER Question 11 OR Question 12

Section B 11

The elevation and plan of a sheet metal recycling bin with a base are given.  
A pictorial view is also shown.

Draw, to the same scale, ignoring the thickness of the metal:

- (a) the end elevation;  
**Show all hidden detail.**
  - (b) the auxiliary plan, showing the true shape of the right-hand opening.  
**Do not show hidden detail.**
- (20 marks)**



PICTORIAL VIEW

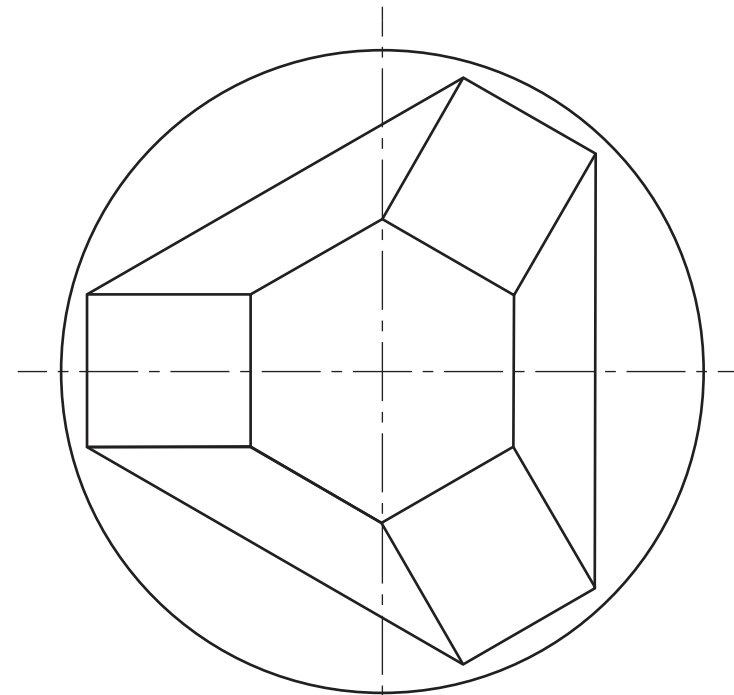

PLAN

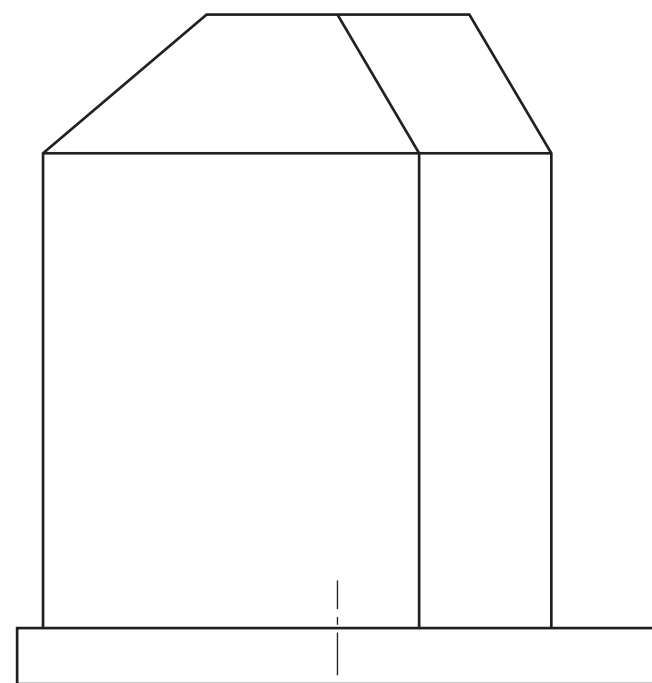

ELEVATION

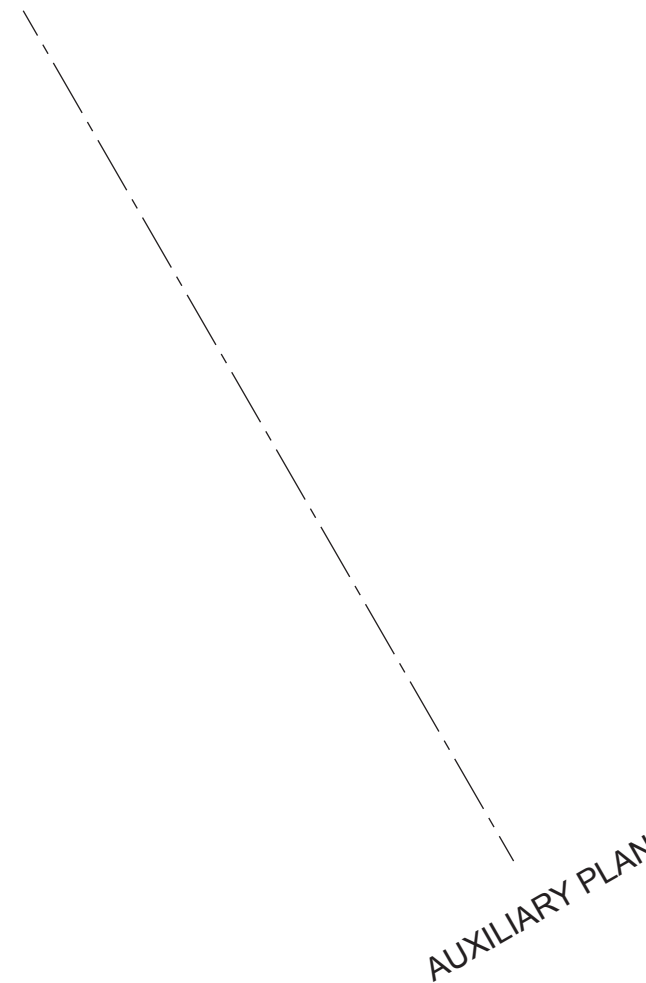

AUXILIARY PLAN

END ELEVATION

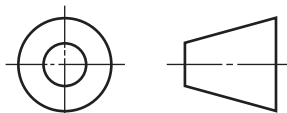

<i>a</i>	
<i>b</i>	
<i>c</i>	
<i>d</i>	
<i>e</i>	
<i>f</i>	
<i>g</i>	
<i>h</i>	
<i>i</i>	
<i>j</i>	
<i>k</i>	
<i>l</i>	
<i>m</i>	
<i>n</i>	

A plan, incomplete elevation and partial auxiliary view of a wall-mounted light fitting are given.

A pictorial view of the fitting is also shown.

Draw, to the same scale:

- (a) the completed elevation;
- (b) the end elevation in the position indicated;
- (c) the development of the canopy using the given starting point.

Show all hidden detail.

(20 marks)

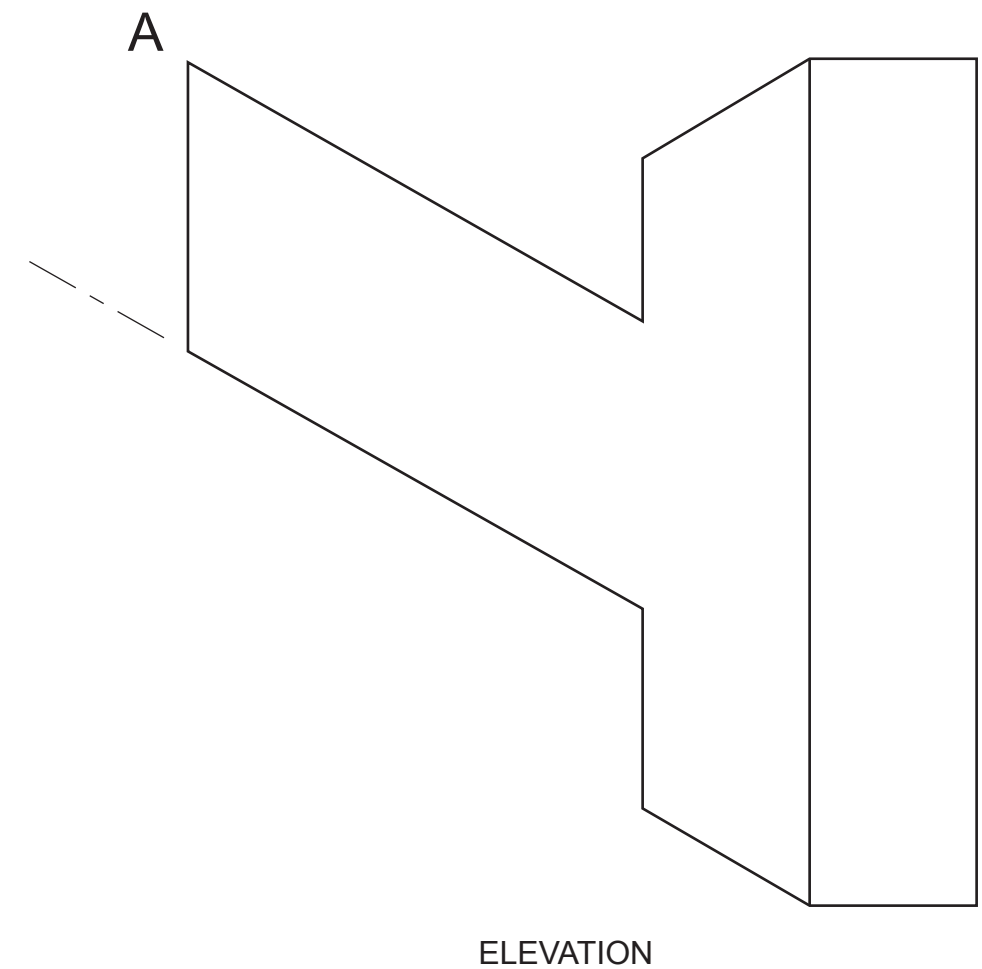
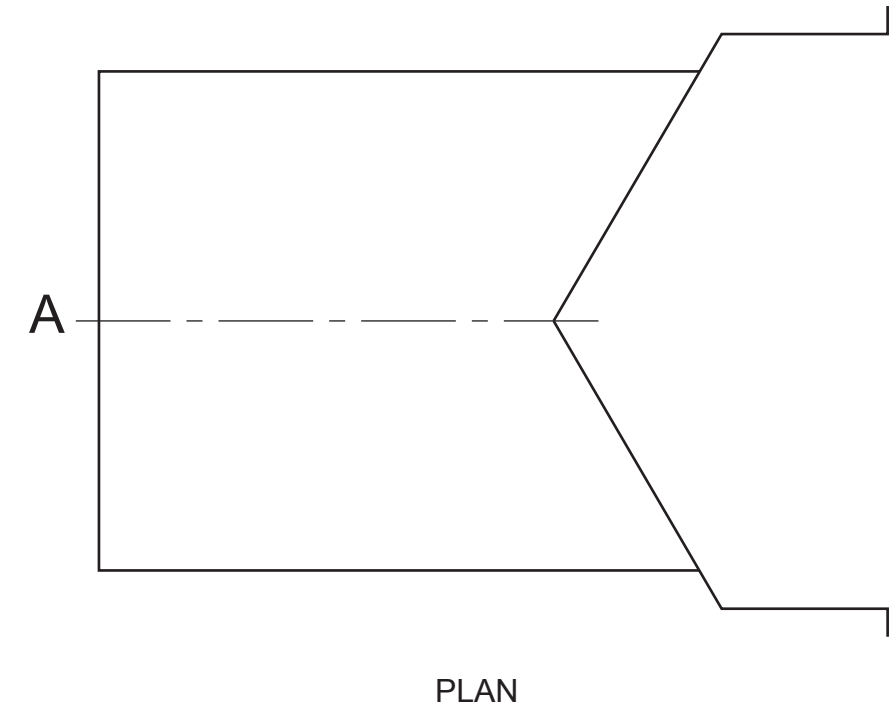
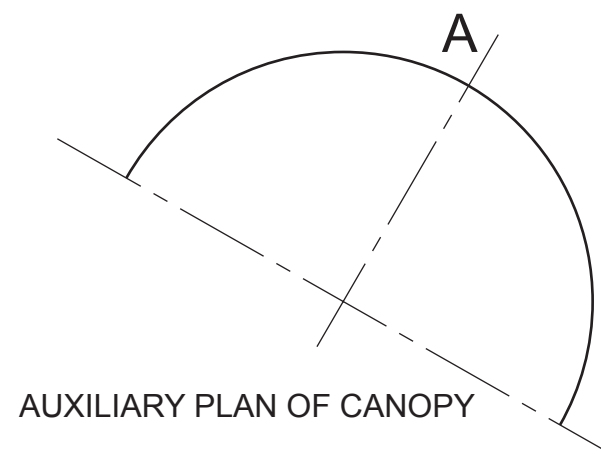
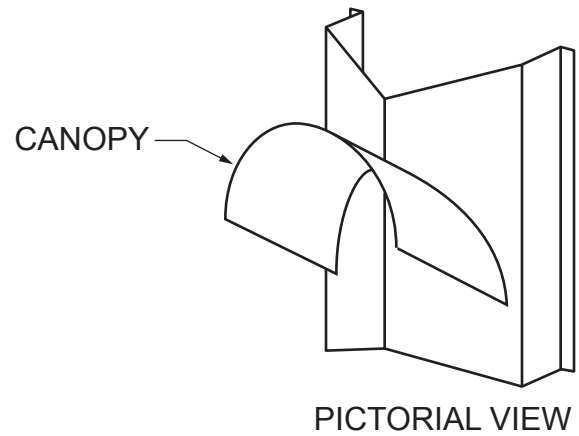

a	
b	
c	
d	
e	
f	
g	
h	
i	
j	
k	
l	
m	
n	

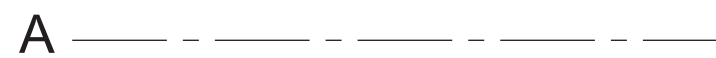

DEVELOPMENT OF CANOPY

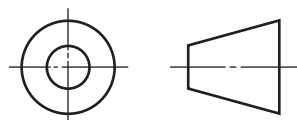

END ELEVATION

[END OF QUESTION PAPER]