

STAPLE HERE

FOR OFFICIAL USE

--	--	--	--	--	--	--	--

**X033/301**

NATIONAL QUALIFICATIONS 2010 THURSDAY, 27 MAY 9.00 AM – 12.00 NOON  
**GRAPHIC COMMUNICATION HIGHER**

Fill in these boxes and read what is printed below.

Full name of centre				Town			
Forename(s)				Surname			
Date of birth	Day	Month	Year	Scottish candidate number	Number of seat		
	<input type="text"/>	<input type="text"/>	<input type="text"/>	<input type="text"/>	<input type="text"/>	<input type="text"/>	<input type="text"/>

1 **140 Marks are allocated to this paper. Section A = 40 marks Section B = 100 marks**

- Candidates should attempt **all** questions in **Section A** and are advised to spend approximately 45 minutes on this section. A supplementary page is included at the end of **Section A** for use if extra space is required.
- Candidates should attempt questions 7a, 7b, 8, 9 and **either** question 10a, 10b or question 11 in **Section B**.
- Read each question carefully before you answer.
- Written answers may be in **ink or pencil**.
- Drawings and sketches **must be in pencil**.
- Dimensions are given in millimetres or as stated.
- Orthographic drawings are in third angle projection.
- At the end of the examination** check that your name is on every sheet; put the sheets in correct numerical order; place this sheet on top of the others; join all sheets together by stapling at the top left-hand corner; before leaving the examination room, you must give these sheets to the Invigilator (if you do not you may lose all the marks for this paper).

Question	Marks
1	
2	
3	
4	
5	
6	
<b>Section A Total</b>	

**EITHER**

7a	
7b	
8	
9	
10a	
10b	
11	
<b>Section B Total</b>	

**OR**

<b>Total Marks A + B</b>	
--------------------------	--



**[BLANK PAGE]**

**A supplementary page is included at the end of Section A for use if extra space is required.**

**2**

(a) State the type of sectional view shown below.

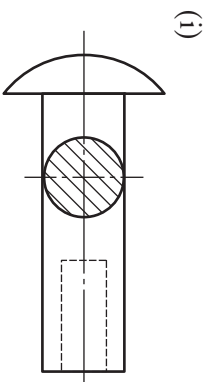

.....

(ii)

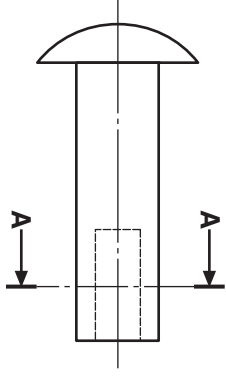

.....

(iii)

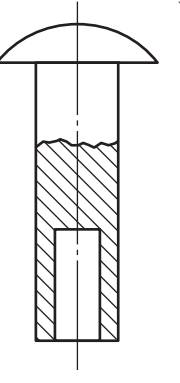

.....

(iv)

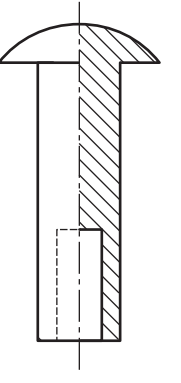

..... 4

(b) State what each of the British Standards conventions shown below represent.

(i)

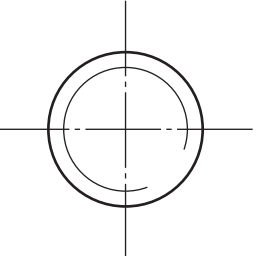

(ii)

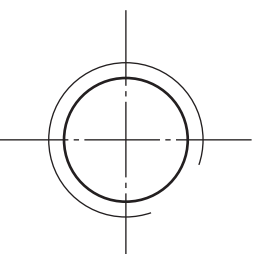

..... 2

**1** (a) Explain clearly what each of the following CAD commands allows the user to do. Sketches may be used to help explain your answers.

(i) Scale .....

.....

(ii) Zoom .....

.....

(iii) Mirror .....

.....

(iv) Pan .....

.....

(v) Rotate .....

.....

(vi) Library .....

.....

(vii) Grid lock/snap .....

.....

(viii) Copy .....

.....

**8**

(b) Explain the operation in relation to paper and pen movement of the following two output devices.

(i) Drum plotter .....

.....

(ii) Flatbed plotter .....

.....

**2**

(10)

Candidate's Name .....

**2**

(6)

3

A pictorial view of a tap wrench is shown. Six sizes are given.

Marks

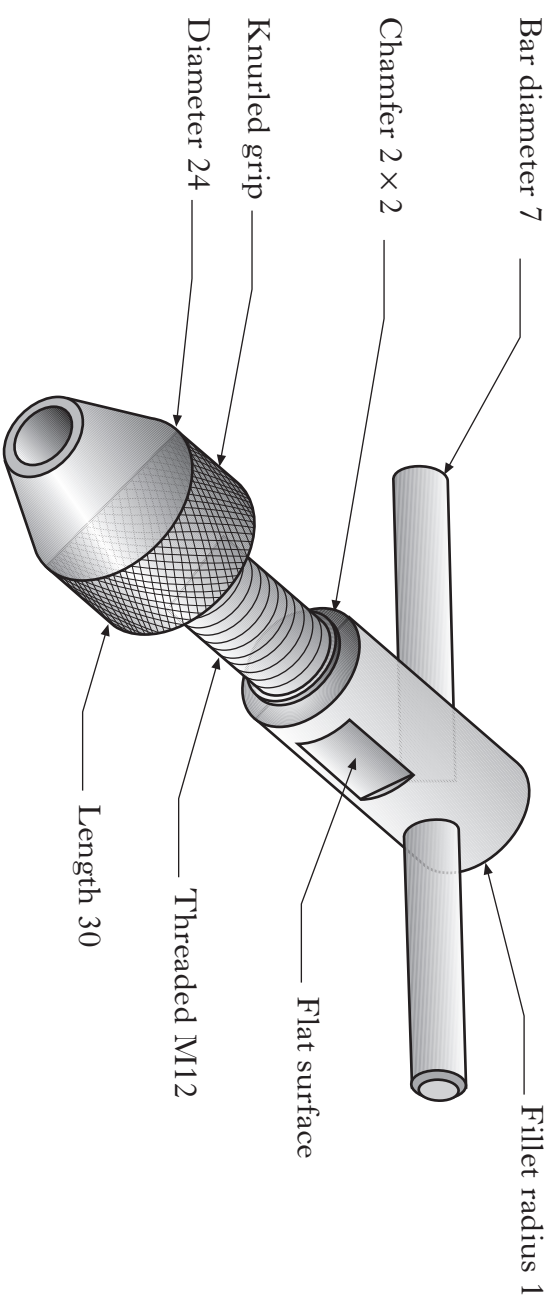

(a) Sketch to British Standards conventions, the six given sizes on the orthographic view below.

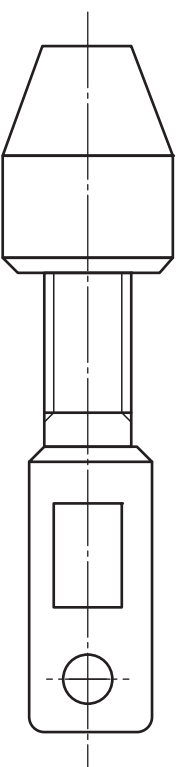

- (b) Sketch, on the orthographic view above, the British Standards convention to indicate:
- (i) the flat surface on the barrel;
  - (ii) the knurled pattern on the chuck.

6

2

(8)

- (i) .....
- (ii) .....
- (iii) .....
- (iv) .....
- (v) .....

(8)

4

An example of a desktop published (DTP) safety leaflet is shown.

Marks

(a) State the desktop publishing effect indicated at A.  
 ..... 1

(b) State the page orientation of the leaflet below.  
 ..... 1

(c) State the desktop publishing terms for each of the features (i) to (vi).  
 ..... 1

**Scotland** A

**Safety advice for Hill Walkers**

**Preparation**

(i) There are several things you can do in advance of your walk. The first question you should ask yourself is "are you fit enough for the challenge?" If not lower your expectations and commence a fitness regime to enable you to meet the challenges of a day out on the hills. You should consult your family doctor first if you have been living a sedentary lifestyle. If you consider that you are fit enough you should then plan a walk within your and your companion's capabilities.

(ii) There is no point in deciding on a 20 mile hike over the top of a hill if you can only walk for around 3 hours.

(iii) Now that you have decided on the route you need to ensure that you have a map of the area and you know how to read it. A compass will be of use to ensure you are walking in the correct direction. A map and compass, and knowing how to use them is a must if you are intending venturing off the beaten track. The next thing to consider is the weather. Check local forecasts on the radio, television or on the internet a few days beforehand and if possible on the day of your walk as it will give you an idea of the weather pattern. If the weather isn't to your liking postpone the walk until suitable weather arrives.

(iv) The following are very useful. The first one divides Scotland into five different mountain regions while the BBC web site allows you to select weather for a particular town or city.

(v) You must also be properly equipped to walk in the hills. A layering system is best but do not use cotton materials as they do not dry very well. This includes jeans. You also need suitable footwear and ensure any new boots have been broken in. Waterproof or rainproof gear should also be carried together with a hat and a pair of gloves.

Figure 1

Hill Walkers Trust

Page 1

(8)

6

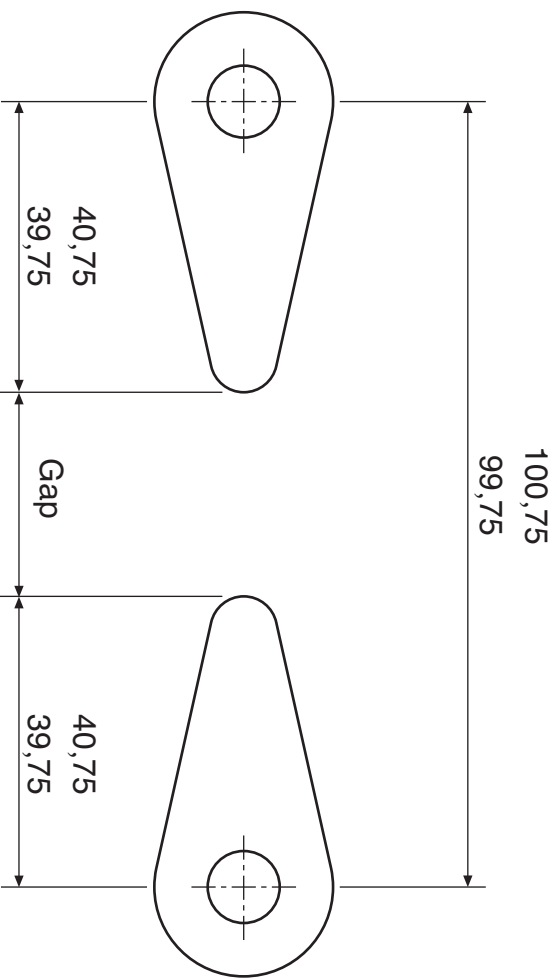

The paddles from a pinball game are shown. The paddles are set at a nominal 100 mm apart centre to centre.  
 The distance between the pivot centre and the end of the paddle is 40 mm with a tolerance of +0.75 and -0.25 applied.

Calculate the maximum and minimum gap between the paddles.  
 (Show all relevant calculations.)

2  
 (6)

5

Some of the many different types of graphics used in the construction industry are shown below.

Describe the purpose and state a suitable scale for each of the plans.

(a) Floor plan

Scale .....

Description .....

2

(b) Site plan

Scale .....

Description .....

2

(c) Block plan

Scale .....

Description .....

2

(6)

(2)

Candidate's Name \_\_\_\_\_

Use this page if extra space is required for answers to Questions 1 to 6.

**Number each answer clearly.**

7a

An elevation and plan of part of a kitchen are given.

Draw a measured 2-point perspective of the kitchen.

The spectator point (SP), plane of projection (PP), ground level (GL), eye level (EL) are given.

Do not show hidden detail. (20 marks)

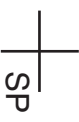
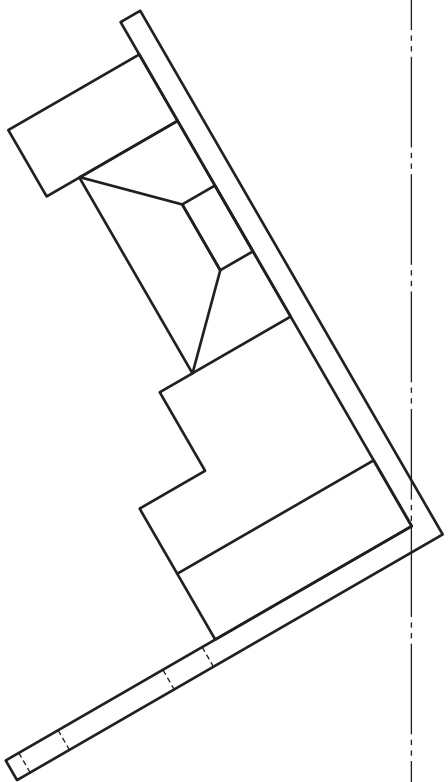
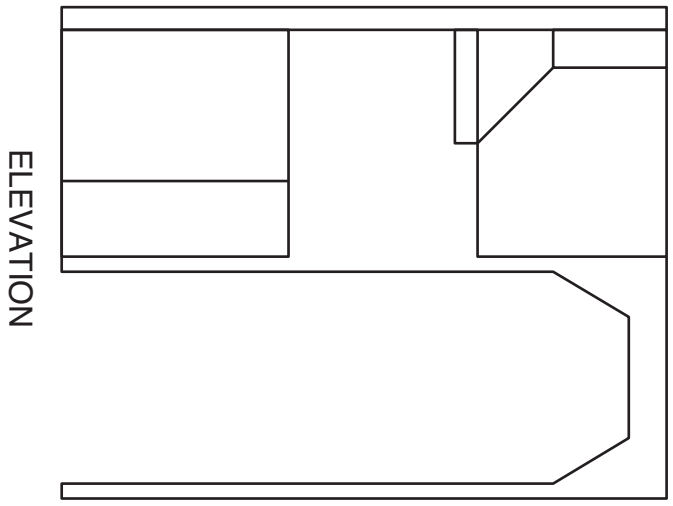
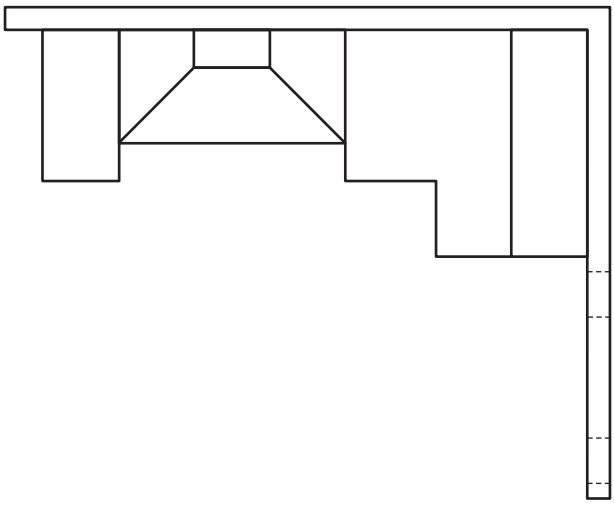

7a

Section B

EL

GL

PP

a	
b	
c	
d	
e	
f	
g	
h	
i	
j	
k	
l	
m	
n	

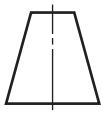
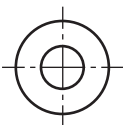

Candidate's Name

[X033/301]

7b

The elevation and plan of a cooker hood are given.

Draw an auxiliary plan of the cooker hood showing the true shape of surface A.

Show all hidden detail.

(10 marks)

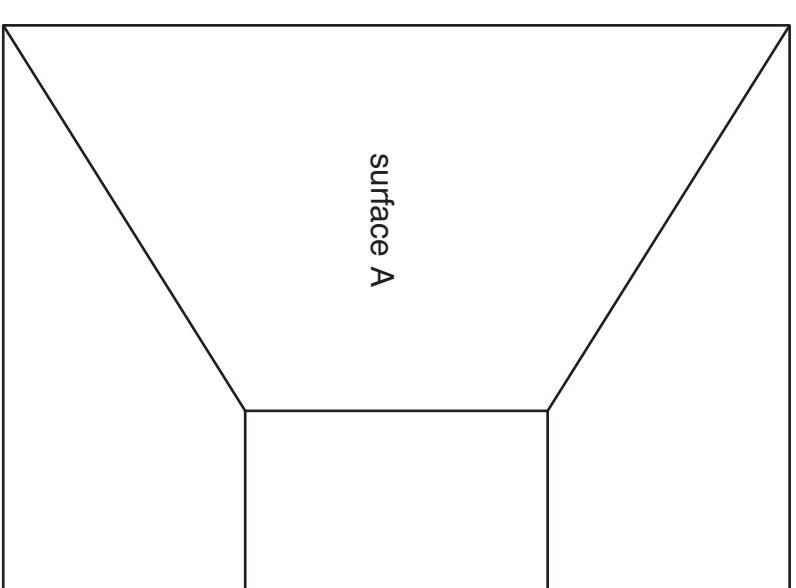

PLAN

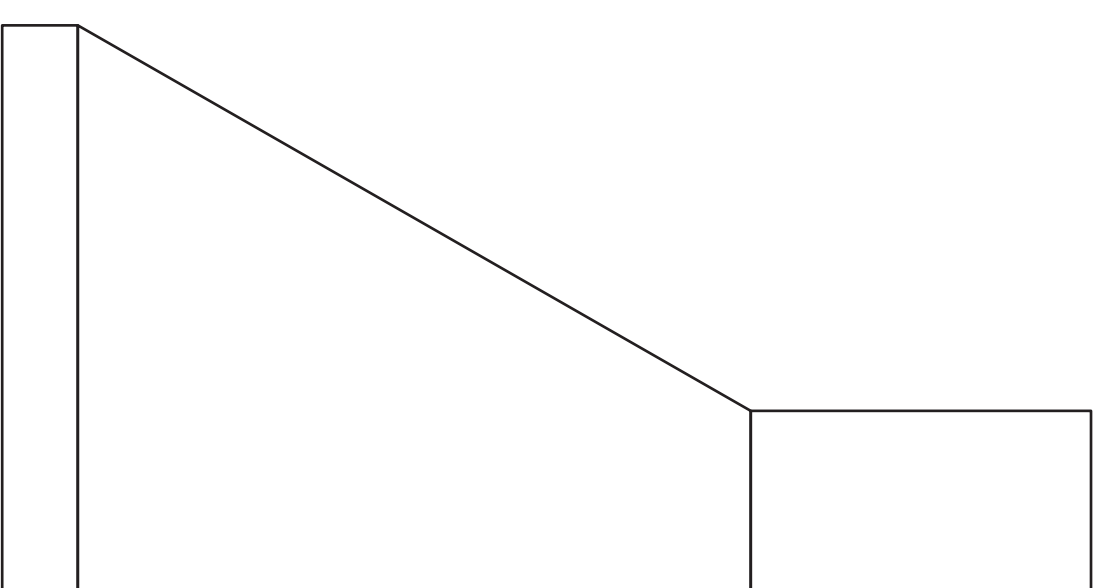

ELEVATION

AUXILIARY PLAN

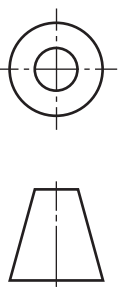

[X033/301]

7b

Section B

a	
b	
c	
d	
e	
f	
g	
h	
i	
j	
k	
l	
m	
n	



The plan and elevation of three parts of a drilling table are shown.

A pictorial view of the assembled parts is also shown.

Draw in the positions indicated on the WORKSHEET on the following page:

- (a) The end elevation of the assembled parts.  
(The top surface of the collar has to be positioned 50 mm from the top of the pillar.)

Show all hidden detail.

- (b) A sectional elevation A-A of the assembled components.  
(The top surface of the collar has to be positioned 50 mm from the top of the pillar.)

Do not show hidden detail.

(30 marks)

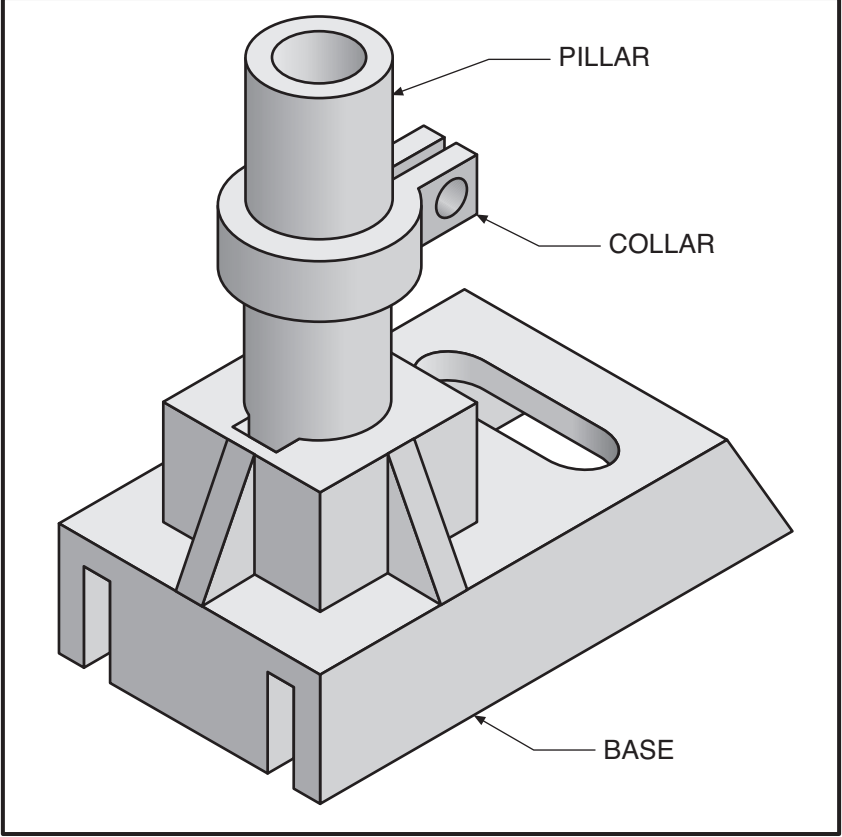

PICTORIAL VIEW OF THE ASSEMBLED PARTS

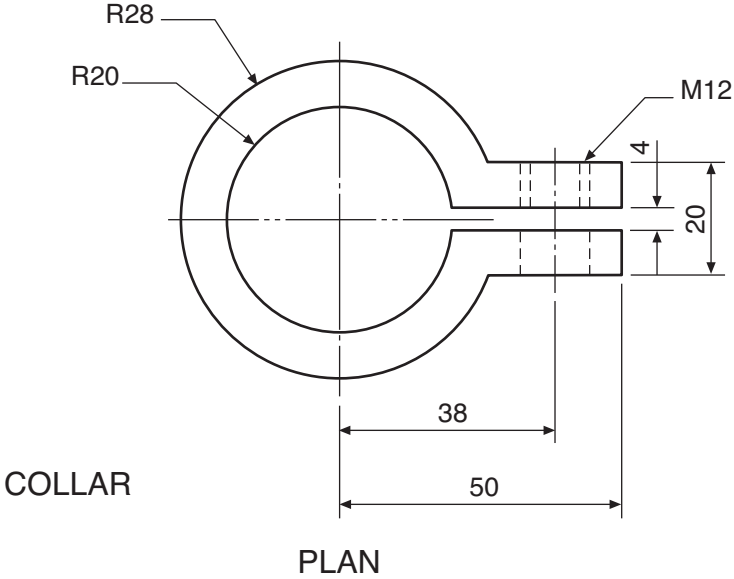

PLAN

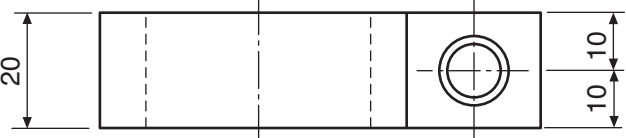

ELEVATION

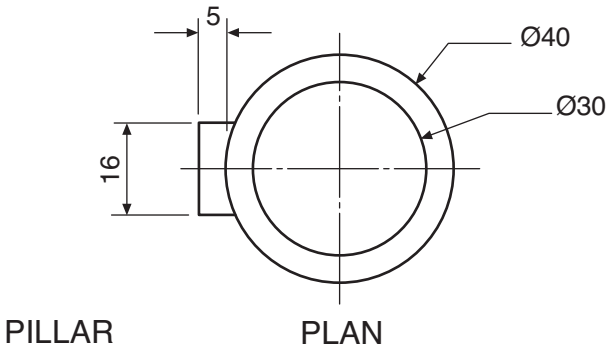

PILLAR

PLAN

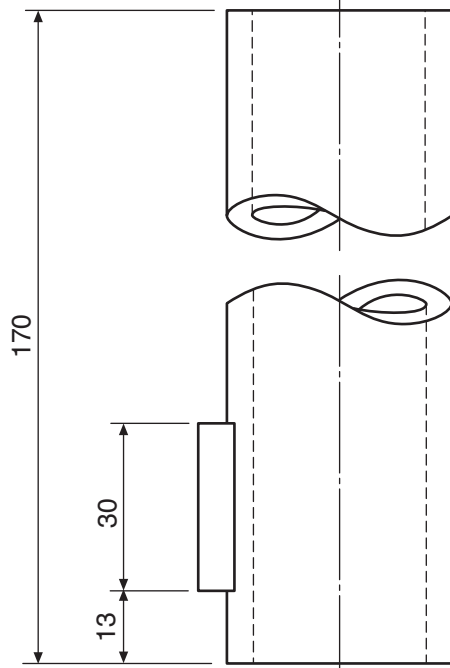

ELEVATION

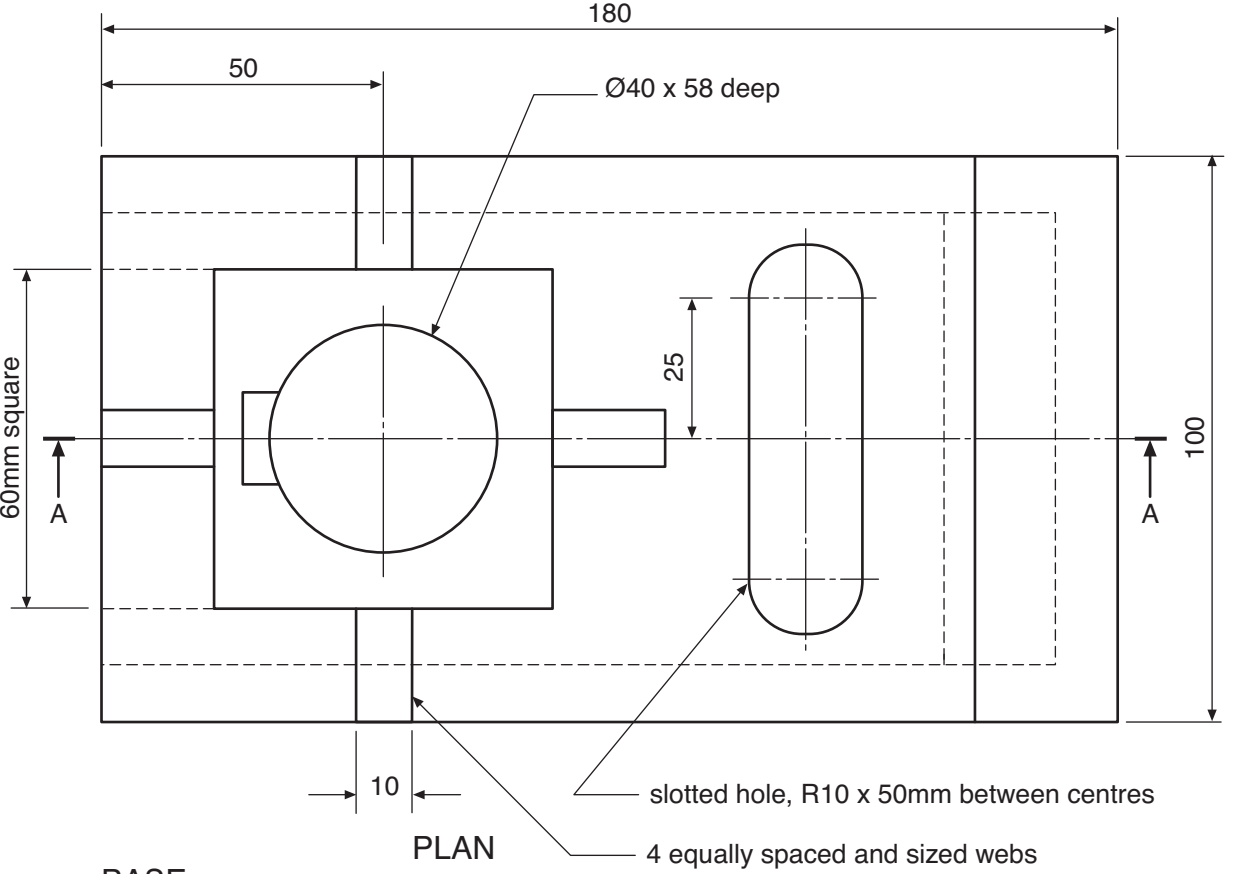

BASE

PLAN

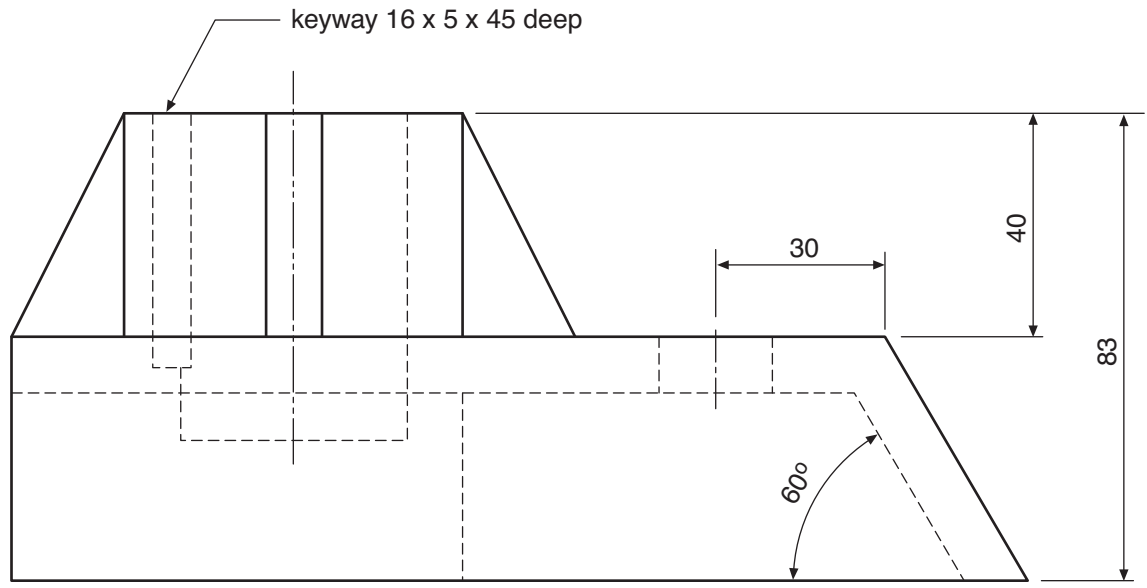

ELEVATION

**[BLANK PAGE]**

<i>a</i>	
<i>b</i>	
<i>c</i>	
<i>d</i>	
<i>e</i>	
<i>f</i>	
<i>g</i>	
<i>h</i>	
<i>i</i>	
<i>j</i>	
<i>k</i>	
<i>l</i>	
<i>m</i>	
<i>n</i>	

A →

A →



SECTIONAL ELEVATION A-A



END ELEVATION

The auxiliary plan, incomplete elevation and incomplete plan of a junction of a cylinder and square pipe are given.

**Draw**, to the same scale:

- (a) the completed plan;
- (b) the completed elevation showing all lines of intersection;
- (c) the half development of the square pipe from **A** to **B**.

**Ignore the thickness of the material.**

**(20 marks)**

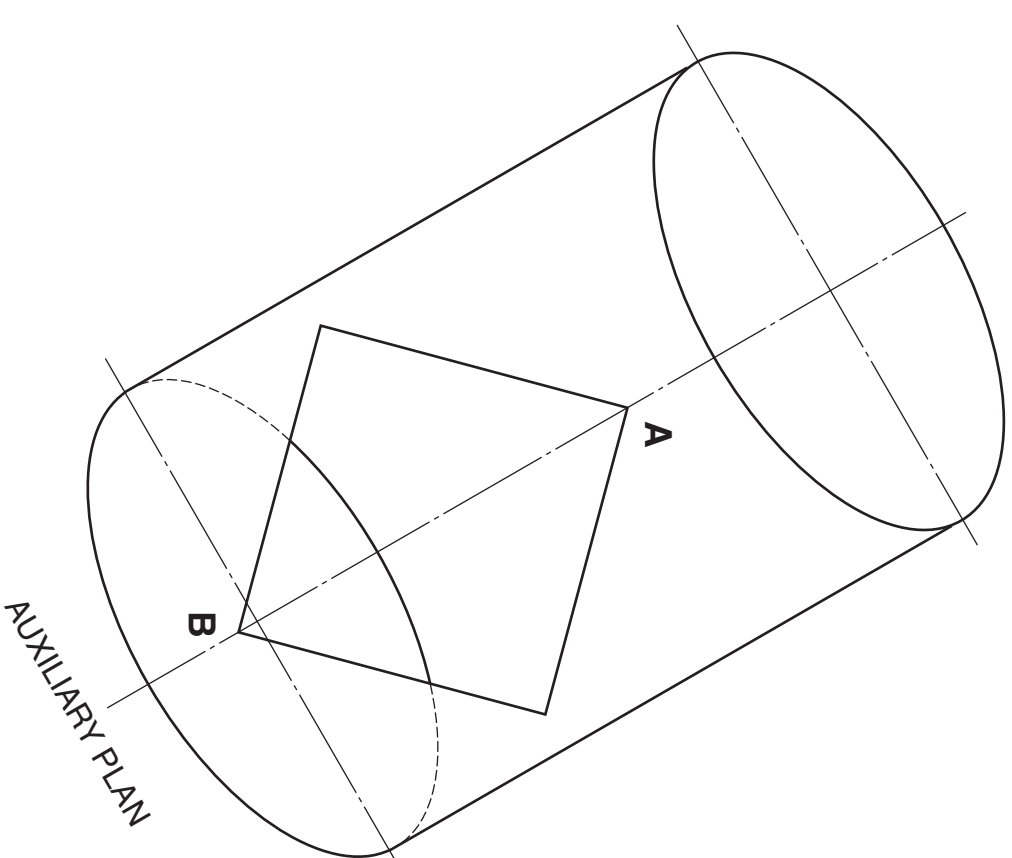
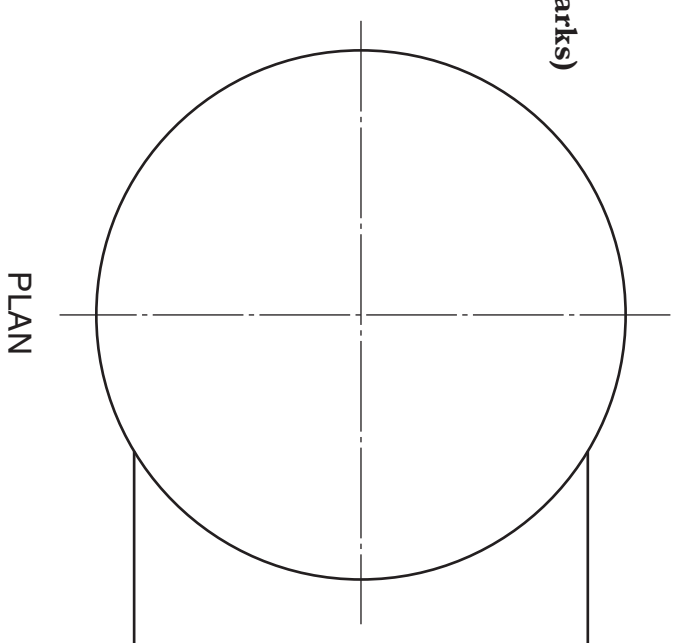

a	
b	
c	
d	
e	
f	
g	
h	
i	
j	
k	
l	
m	
n	



HALF DEVELOPMENT

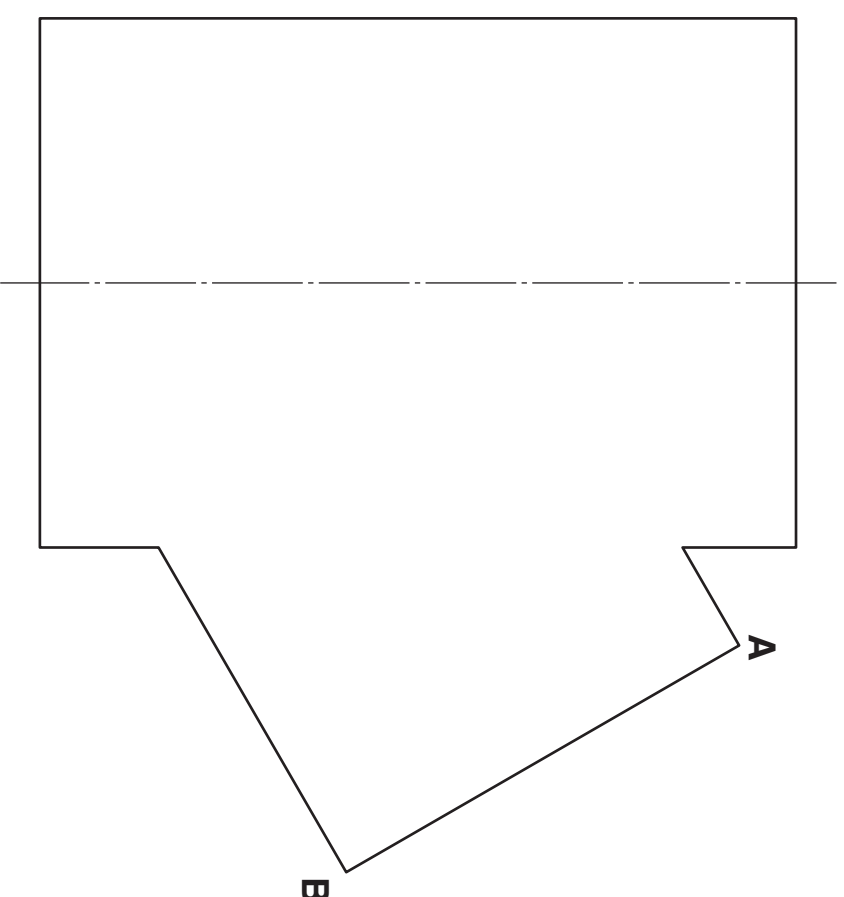

ELEVATION

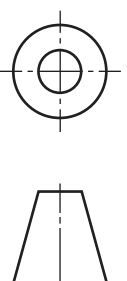

Three views of a child's seat are given.  
**Draw a cabinet oblique view of the seat using the given start.**  
**Do not show hidden detail.**  
**Lines at 45° should be drawn half full size.**  
**Ignore the thickness of the material. (10 marks)**

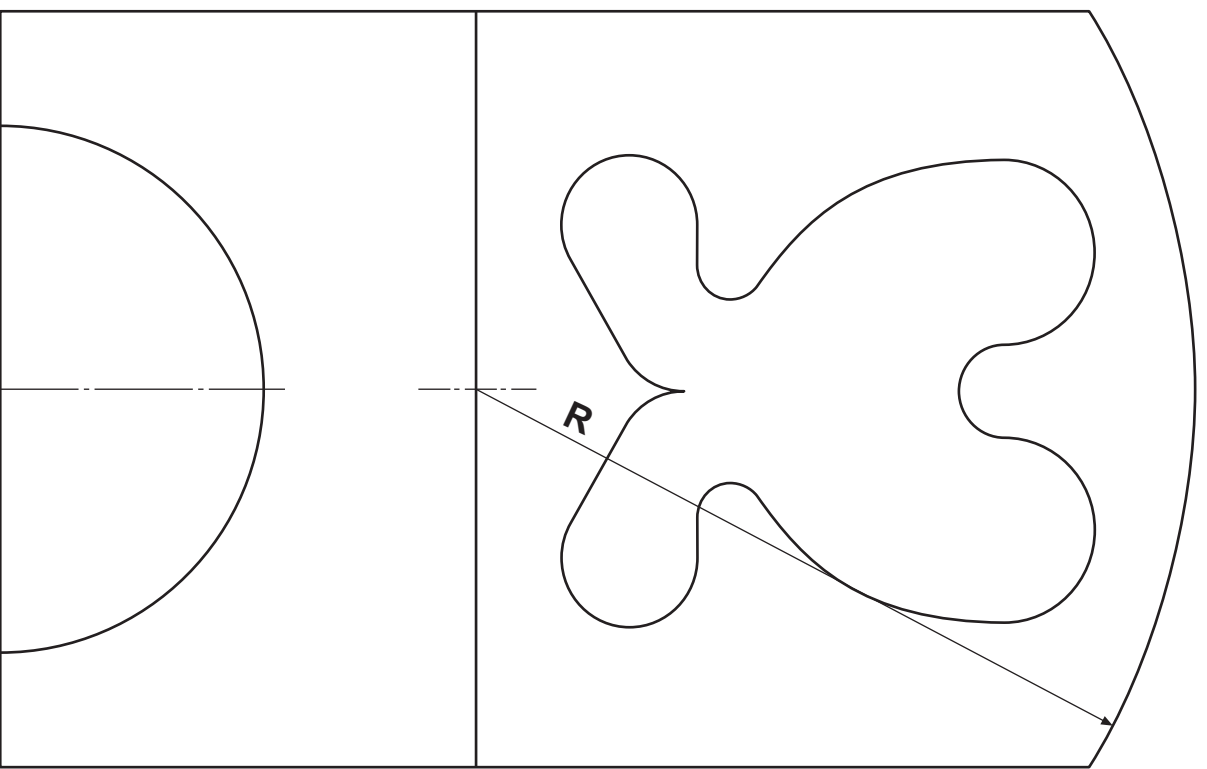
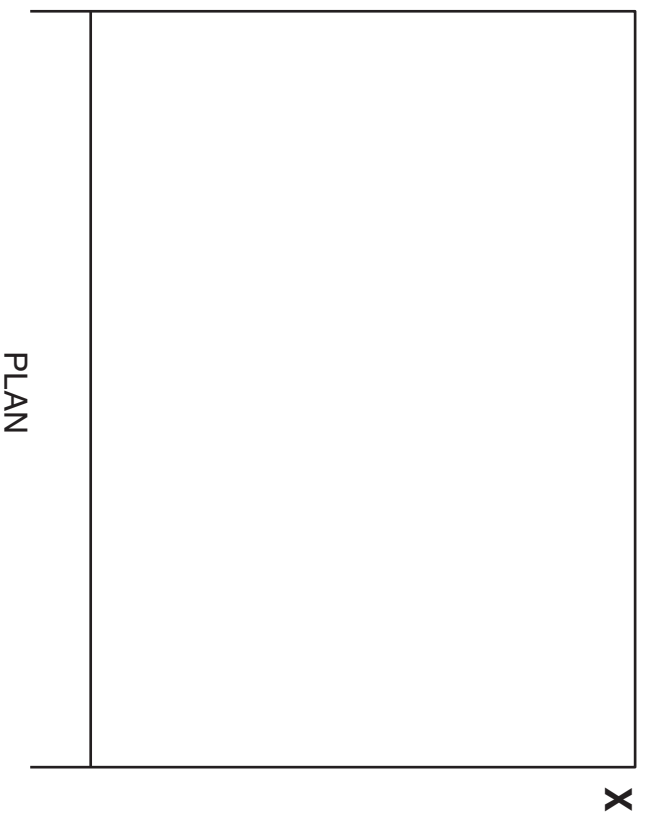

[X033/301]

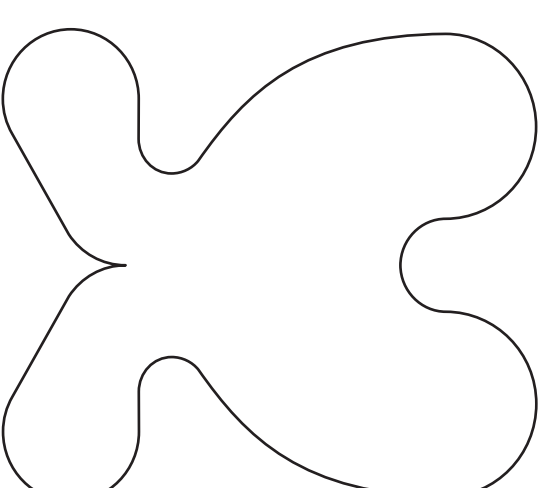
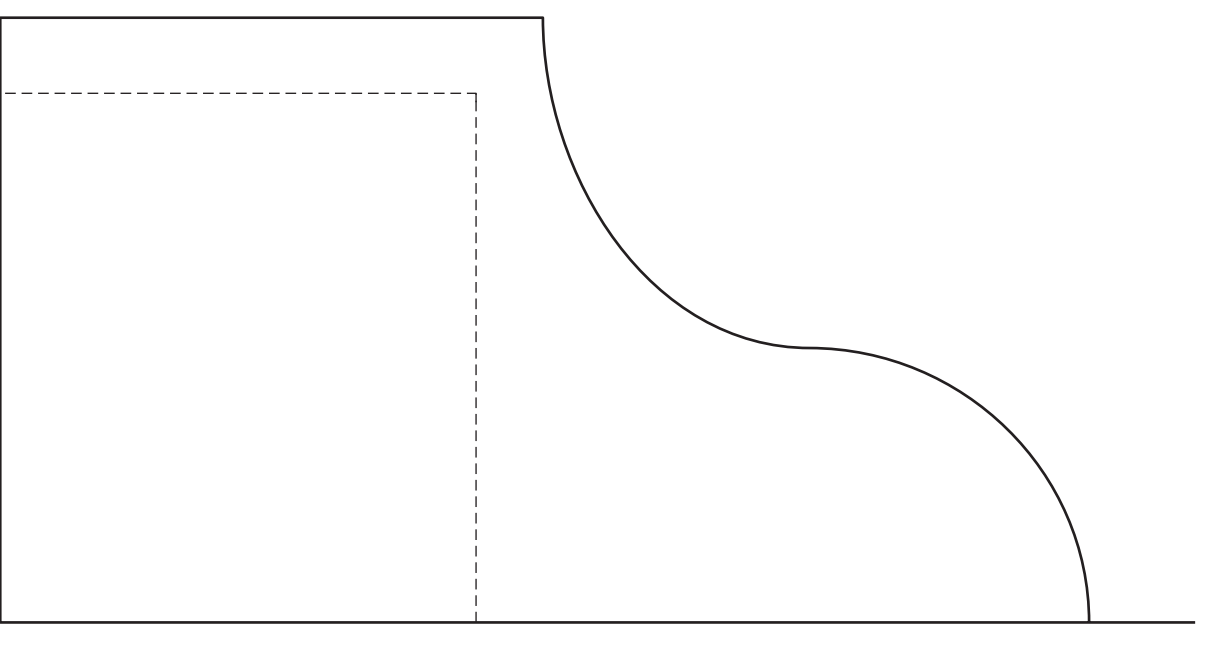
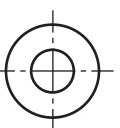

a	
b	
c	
d	
e	
f	
g	
h	
i	
j	
k	
l	
m	
n	

OBLIQUE

Candidate's Name \_\_\_\_\_

A sketch of the design for the back of the child's seat is shown, not to scale.

Draw full size using the given start **X**, the symmetrical left half of the design.

Show clearly the centres used to draw all the arcs.

Do not show dimensions.

(10 marks)

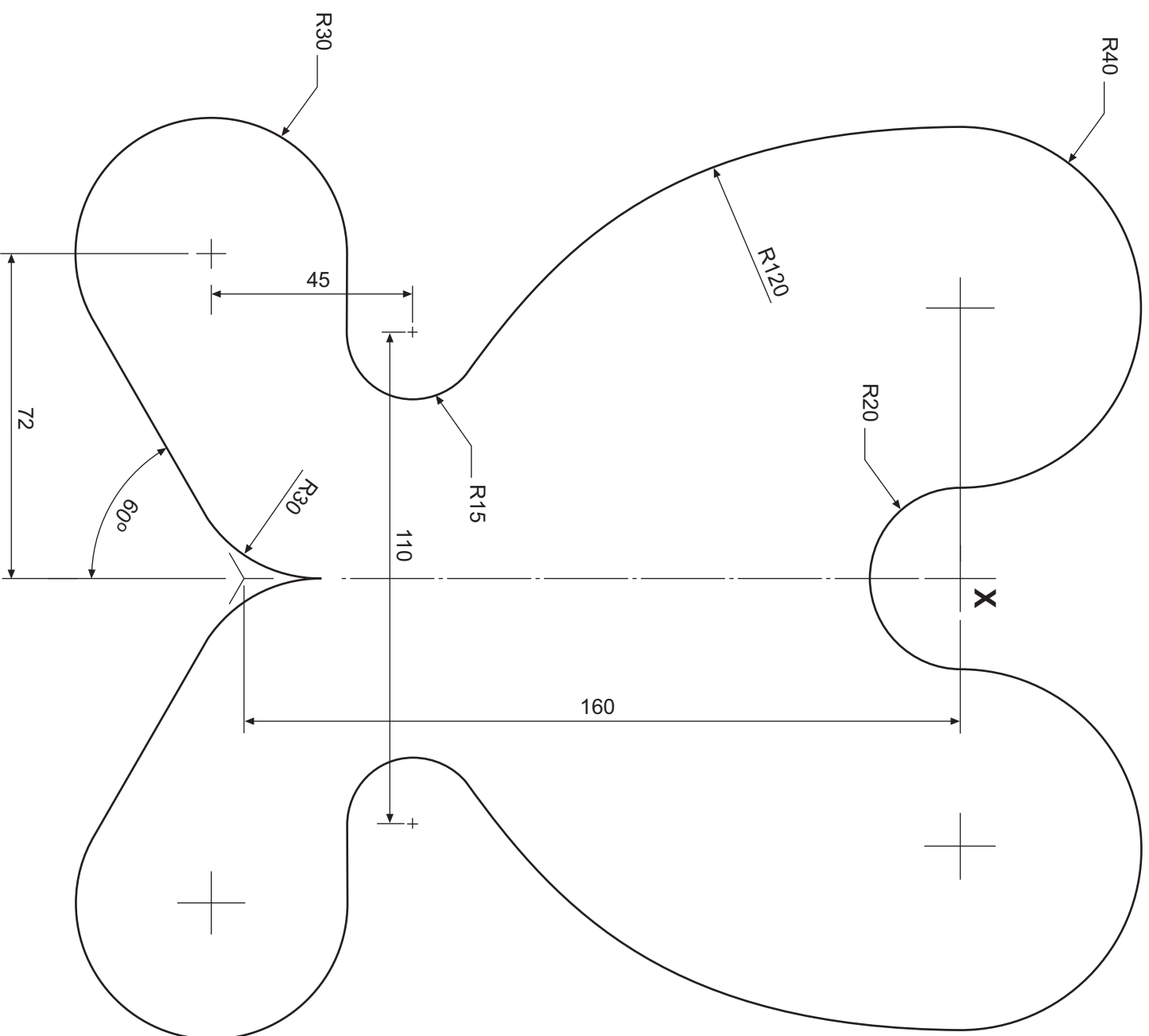

NOT TO SCALE

[X033/3011]

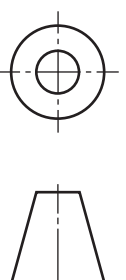

a	
b	
c	
d	
e	
f	
g	
h	
i	
j	
k	
l	
m	
n	

The elevation and plan of part of a cross trainer exercise machine, along with a pictorial view are given.

Draw, an isometric view of the cross trainer part.

(Use the given start O)

Do not show hidden detail.

(20 marks)

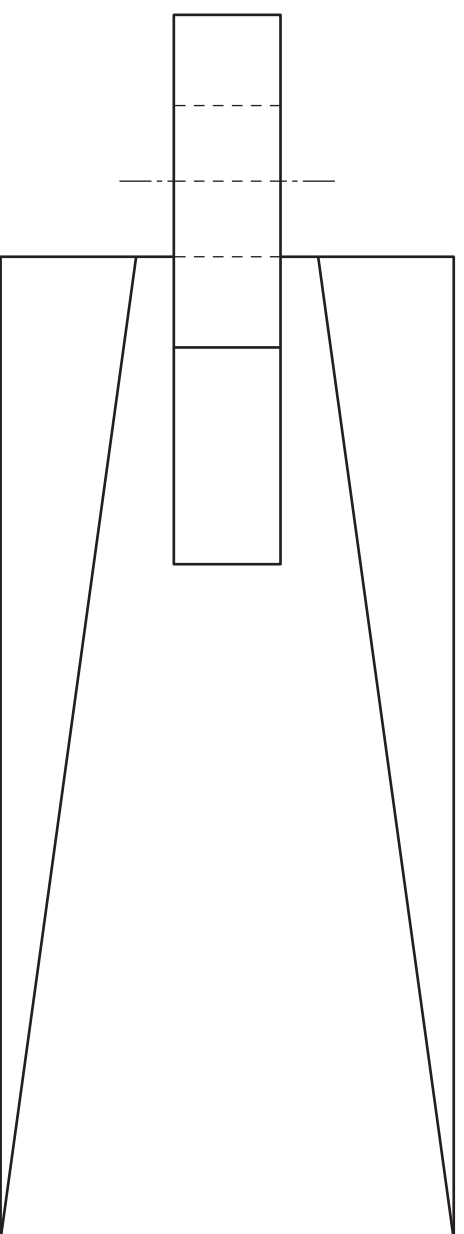
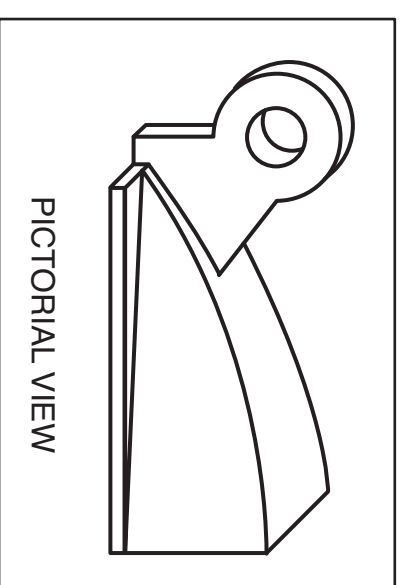

PLAN

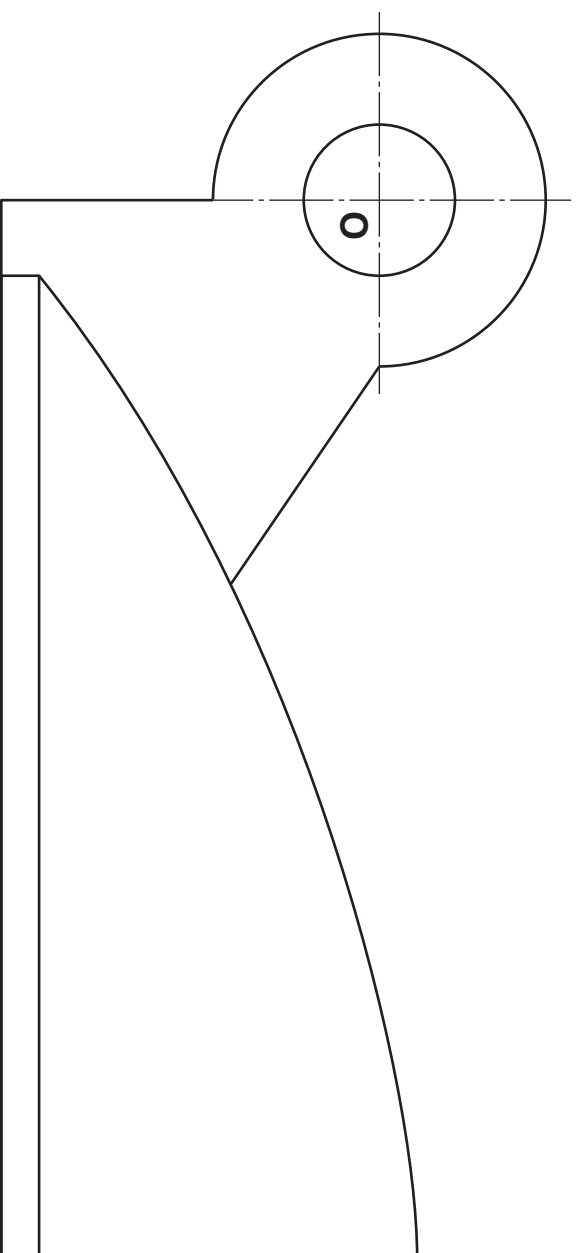

ELEVATION

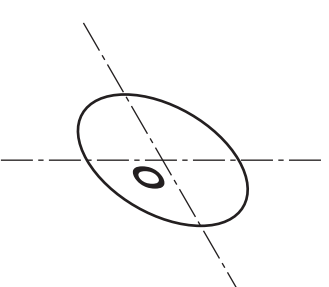

ISOMETRIC

[X033/301]

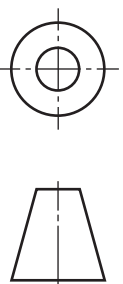

[END OF QUESTION PAPER]

Candidate's Name \_\_\_\_\_

a	
b	
c	
d	
e	
f	
g	
h	
i	
j	
k	
l	
m	
n	

**[BLANK PAGE]**